

# ***PERTRONIX***

*PERFORMANCE PRODUCTS*

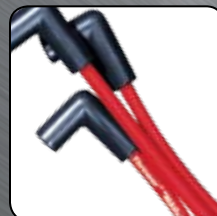

***Quality Products for Over 40 Years***



***2010***

440

**PERTRONIX**<sub>INC.</sub>

**We are pleased to present our 2010 ignition catalog!**

**Our customers are our biggest asset and we would like to thank you for your continued support of the PerTronix performance brands!**

**We have continued to be the world leader in the point replacement business offering significantly more applications than all of our competitors combined. And now with the recent Ignitor®III product release, electronic ignition module technology has moved “up and to the right”. Featuring multiple sparks throughout the entire RPM range as well as a high resolution rev limiter set by the user all inside the distributor, you now can have “ignition box” performance without the box! Look for new products throughout our catalog.**

**In November 2008 PerTronix purchased the assets of JBA Performance Exhaust. We are continuing the JBA 22 year tradition of building the highest quality, best fitting headers and exhaust systems with application emphasis on Late Model Trucks, SUV's and Muscle Cars. JBA is a welcome addition to our ever growing family of exhaust brands including Doug's Headers, Patriot Exhaust Products and Thunderbird Exhaust Products.**

**QUALITY**



**SERVICE**



**PERFORMANCE**



The Pertronix sponsored Duttweiler powered Hairston Motorsports and Racing 2007 GTO continues to impress the Pro-Street world by running the quickest ever elapsed time of 6.23 seconds at 231.30 MPH and recently set the national speed record of 230.23 MPH at the famous Famoso Raceway in Bakersfield, California during a West Coast Hot Rod event. Visit [www.pertronix.com](http://www.pertronix.com) and follow the Team's performance.

# CHECK OUT WHAT'S NEW



IGNITOR III Ignition modules featuring multiple spark output and integrated rev limiter.



Flame-Thrower III 45,000 volt coils are the perfect match for Ignitor III systems.



New billet distributors for AMC, Buick, Oldsmobile, Pontiac, Chevy 409 & 4.3L, and GM L6 Engines. Also check out our new line up of Ignitor III equipped billet distributors.

## TABLE OF CONTENTS

<b>Electronic Ignition Conversions</b> .....	2
Ignitor / Ignitor II / Ignitor III Features .....	2
Ignitor III Applications .....	4
Ignitor & Ignitor II Automotive Applications .....	5
Ignitor & Ignitor II Aftermarket Distributor Applications .....	14
Ignitor & Ignitor II Application by Distributor Number .....	15
Ignitor & Ignitor II Marine Applications .....	17
Ignitor & Ignitor II Industrial Applications .....	19
Ignitor & Ignitor II Agricultural Applications .....	27
<b>Flame-Thrower® Performance Distributors</b> .....	32
Ignitor III Equipped Billet Distributors .....	33
Ignitor II Equipped Billet Distributors .....	35
Magnetic Trigger Billet Distributors .....	37
Ignitor II Equipped Billet Marine Distributors .....	39
High Performance Distributors .....	40
Performance Distributors .....	41
HEI Distributors .....	44
<b>Tune-up Parts and Accessories</b> .....	46
Ignition Modules .....	47
<b>Igniton Coils</b> .....	48
Flame-Thrower Canister Coils .....	48
Flame-Thrower HV & HC E-core Coils .....	50
Flame-Thrower E-core coils .....	51
<b>Ignition Box and Rev Limiter</b> .....	52
Second Strike .....	52
Digital Rev Limiter .....	53
<b>Spark Plug Wire Sets</b> .....	54
Flame-Thrower MAGx2 8mm wires .....	54
Flame-Thrower "Stock Look" 7mm wires .....	58
<b>Industrial Distributors</b> .....	62



HC (HIGH CURRENT) e-core coils charge extremely fast and produce 60,000 volts for HIGH RPM applications.

## IGNITOR® ELECTRONIC IGNITION

For over thirty years, the Ignitor has proven itself in applications ranging from race cars to tractors. The Ignitor replaces breaker points and troublesome factory electronic ignitions with a dependable, self contained and maintenance free electronic ignition system. The Ignitor has been called the "stealth" ignition because of its quick installation and nearly undetectable presence under your distributor cap. There is no "black-box" to clutter the engine compartment. For optimal performance, use the Ignitor with Flame-Thrower 40,000 volt coils.

### FEATURES

- Delivers twice the voltage to the spark plugs, increasing horsepower, fuel economy, and spark plug life.
- 2:1 improvement over "points" in current fall time for increased coil output.
- Rotating cobalt magnets trigger a Hall Effect integrated circuit . . .no points to burn, . . .no moving parts to wear out.
- Epoxy molding makes our module impervious to dirt, oil, grease and moisture.
- Stable timing . . .no need for any adjustments.
- Will trigger most multi-spark CD ignitions.
- Available for 6 and 12-volt negative and positive ground systems.
- Legal in all 50 states and Canada. (C.A.R.B. E.O. #D-57-22)
- Guaranteed for 30 months... We Stand Behind It!



### Ignitor vs. Breaker Point Energy

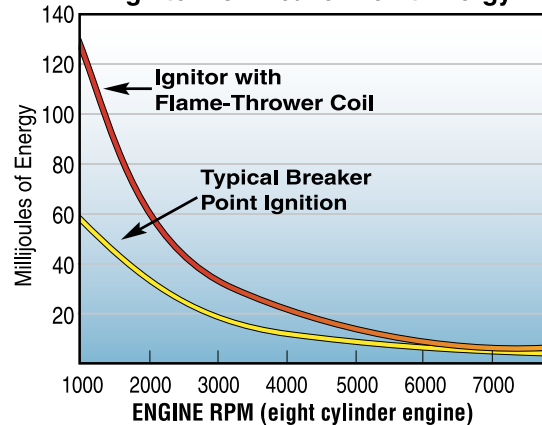

## Ignitor® II ELECTRONIC IGNITION

The Ignitor II has many of the same great features that the Ignitor has, but its smarter. Ignitor II units sense the coil current level and use a powerful micro controller to adjust the dwell. Variable dwell helps to maintain peak energy throughout the entire RPM range. Ignitor II systems develop up to 4 times more energy between 3000 and 5000 RPM than standard ignition systems. High RPM performance is improved when used with the Flame-Thrower II super low resistance (0.6 ohms) 45,000 volt coils.

### FEATURES

- Adaptive dwell maintains peak energy throughout the entire RPM range, reducing misfires while improving engine performance.
- Develops on average 4 times more available energy between 3000 and 5000 RPM, and 2 times more available plug voltage.
- Compensates for inherent electronic delay by adjusting the spark timing throughout the entire RPM range.
- Synchronized peak current and spark timing reduces heat build-up.
- Senses startup and develops more energy for quicker, easier starting.
- Built in reverse polarity and over current protection shuts down the system, preventing component damage.
- Legal in all 50 states and Canada. (C.A.R.B. E.O. #D-57-22)
- Guaranteed for 30 months... We Stand Behind It!



### Adaptive Dwell Control

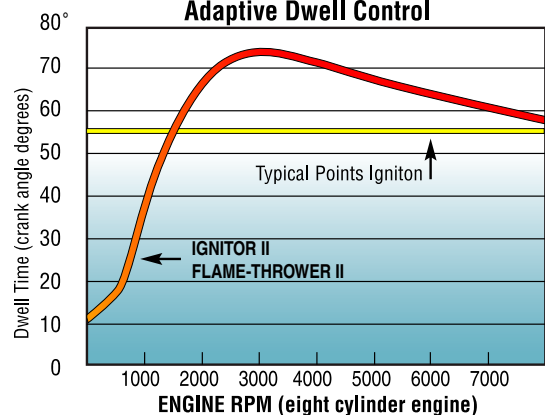

# Ignitor<sup>®</sup> III ELECTRONIC IGNITION

Our all new Ignitor III ignition modules are designed for the serious performance enthusiast who demands serious power. You have seen the performance increases the Ignitor and Ignitor II series of electronic ignitions have brought. Now get ready for more... 5 times more spark energy than points systems. Ignitor III modules provide ignition box performance... without the "box"! For the maximum Ignitor III benefit, select one of our Flame-Thrower III or HC ignition coils from the coil section of this catalog.

**NEW**



## FEATURES

- Multiple sparks thru the entire RPM range.
- Integrated digital REV limiter with LED feedback for precise RPM setting.
- Memory safe function stores settings eliminating unintended changes to Rev limit.
- Adaptive dwell maintains peak energy throughout the entire RPM range, reducing misfires while improving engine performance.
- Peak current level is reached just prior to spark for maximum energy without the heat build-up, increasing coil performance and module reliability.
- Adjusts spark timing at higher RPMs to compensate for the inherent electronic delay.
- Senses startup and increases energy for quicker, easier starting.
- Thermal clad surface mount construction for superior reliability.
- Built-in reverse polarity and over current protection shuts down the system, preventing component damage.
- Not compatible with CD or Multi-Spark boxes.
- Legal in all 50 states and Canada. (C.A.R.B. E.O. #D-57-22)
- Guaranteed for 30 months... We Stand Behind It!

**Ignitor III vs. Breaker Point Energy**

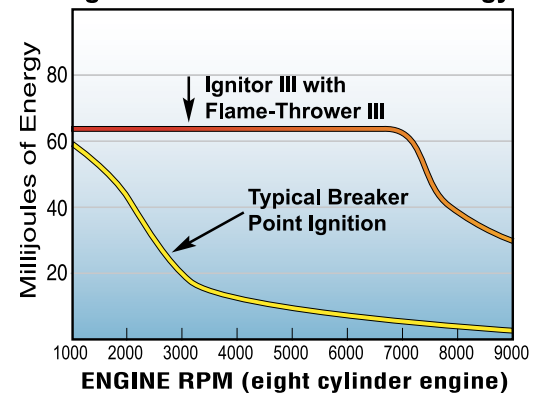

ELECTRONIC IGNITION CONVERSIONS

## FEATURE COMPARISON

**IGNITOR<sup>®</sup> Ignitor<sup>®</sup> II Ignitor<sup>®</sup> III**

Fits entirely inside the distributor. No "Black Box" to clutter the engine compartment	✓	✓	✓
Stable timing... No need for adjustment	✓	✓	✓
Epoxy molded module makes module impervious to dirt, oil, grease and moisture	✓	✓	
Hall Effect integrated circuit.. No points to burn no moving parts to break	✓	✓	✓
Surface Mount Technology	✓	✓	✓
Legal in all 50 states and Canada (C.A.R.B. E.O. #D-57-22)	✓	✓	✓
Compatible with most point type ignition coils	✓	✓	✓
Adaptive dwell control maintains peak energy throughout the entire RPM		✓	✓
High RPM timing correction		✓	✓
Engine Start-up energy boost		✓	✓
Reverse polarity and over current protection		✓	✓
Compatible with low resistance ignition coils		✓	✓
Thermal Clad construction			✓
Integrated adjustable REV Limiter with LED feedback			✓
Multi-spark ignition			✓

## APPLICATION NOTES

The Ignitor III is a high performance ignition system with special application and operational requirements. It is imperative that applications equipped with resistance wires or ballast resistors be modified according to the installation manual. In all applications in order to achieve the advertised performance gains and system reliability, the integrity of the electrical system should be checked.

- For use on 8 cylinder engines
- 12 volt negative ground systems
- Requires 12-14 Volts
- Must use suppression core ignition wires
- Not for use with CD or multiple spark systems
- Lobe sensor design triggers off the point cam or reluctor and does not require a magnet sleeve
- Not intended for marine use.

### 71181 FOR DELCO DISTRIBUTORS

This kit takes just a few minutes to install and is hidden entirely under the distributor cap. Developed for 1957-74 Delco point type distributors with mechanical advance weights on top.



71181

- |                   |                    |
|-------------------|--------------------|
| 1957-74 AMC       | 1957-74 GMC        |
| 1957-74 Buick     | 1966-74 Jeep       |
| 1956-74 Cadillac  | 1956-74 Oldsmobile |
| 1964-74 Checker   | 1957-74 Pontiac    |
| 1957-74 Chevrolet | 1960-66 Studebaker |

### 71281 FOR MOTORCRAFT DISTRIBUTORS

Our 71281 kit retrofits Motorcraft single point vacuum advance distributors. We have completely redesigned the advance plate assembly utilizing a custom nylon glide hub which provides smooth trouble free operation.



71281

- |                     |                 |
|---------------------|-----------------|
| 1957-74 Ford        | 1957-74 Mercury |
| 1957-74 Ford Trucks | 1971-72 Pantera |
| 1957-73 Lincoln     |                 |

### 71381A FOR CHRYSLER DISTRIBUTORS

71381A fits Chrysler aluminum bodied single point distributors with vacuum advance. This kit features a completely redesigned advance plate assembly utilizing a custom nylon glide hub which provides smooth trouble free operation.



71381A

- |                  |                  |
|------------------|------------------|
| 1962-75 Chrysler | 1959-72 Plymouth |
| 1960-72 Dodge    |                  |

### 71281D FOR DUAL POINT MOTORCRAFT DISTRIBUTORS

Dual point and dual point vacuum advance Motorcraft distributors which were used in high performance Ford, Mercury and Pantera applications will certainly benefit from our 71281D Ignitor III conversion. This kit simply installs in place of the points and offers performance levels well beyond the reach of points systems.



71281D

- |                 |                 |
|-----------------|-----------------|
| 1960-72 Ford    | 1972-74 Pantera |
| 1960-73 Mercury |                 |

### 7HO-181 FOR HOLLEY GOLD BOX DISTRIBUTORS

Holley gold box distributors have never before been known for their performance or reliability... until now. We've developed this 7HO-181 Ignitor III system to replace the factory electronics. 7HO-181 fits entirely within the distributor and triggers off the reluctor.



7HO-181

- 1972-81 IHC Trucks

### 7ML-181 FOR MALLORY POINT TYPE DISTRIBUTORS

Tired of replacing points in your Mallory single or dual point non-vacuum distributor? Want more power? Our 7ML-181 will install in just minutes and has all the features you would expect from a high performance ignition but fits entirely in the distributor.



7ML-181

## APPLICATION NOTES

Great effort has gone into insuring the accuracy of this guide. The following pages represent the most common makes and models of each application. To insure that you select the correct part number, use these general guidelines:

- Read all footnotes before ordering.
- Unless otherwise noted, part numbers listed represent 12-volt negative ground kits. Many kits are available in 6-volt negative ground, as well as 6 and 12-volt positive ground. Add an N6, P6 or P12 suffix to the part number when ordering.
- Applications are based on the vehicle's original equipment.
- An "LS" suffix indicates a Lobe Sensor version. Lobe Sensor technology senses the point cam, and does not use a magnet sleeve or magnet ring.
- Compatible coils can be found in the coil section of this catalog.
- If your application is not listed please contact us for information on possible custom kits.
- New applications appear in red.

Year	Cyl	Model	Footnotes	Dist No.	Dist Make	IGNITOR	Ignitor® II
<b>ALFA-ROMEO</b>							
1969-70	4	All	34	231100045	Bosch	2848	
1965-78	4	Giulia	13		Marelli	MR-LS1	
1966-68	4	Giulia, Spider	55	231100041	Bosch	1844	
1967-68	4	Sprint GT, Veloce	55		Bosch	1844	
1969-70	4	All	13	S103B	Marelli	MR-LS2	
1969-72	4	Berlina	13		Marelli	MR-LS1	
1969-73	4	Gt Veloce	13	S166B	Marelli	MR-LS1	
1969-79	4	Spider Veloce	13	S145C, CX, S166B	Marelli	MR-LS1	
1971-75	4	Alfetta, GT, 2000 Berlina GT & Spider Veloce			Bosch	1847V	
1972-79	4	Alfetta	13	S145C, CX, S166B	Marelli	MR-LS1	
1974	4	Spider	13	S145C, CX, S166B	Marelli	MR-LS1	
1975-78	4	Alfasud, TI, 5M, Sprint			Bosch	1847V	
1976-78	4	Romeo F12 (Versolone Benzina)			Bosch	1847V	
1977-81	4	Alfetta 1.6, 1.8, 2.0 Litre			Bosch	1847V	
1977-81	4	GTV 2000			Bosch	1847V	
<b>AMC</b>							
1977-79	4	Concord, Gremilin, Spirit			Bosch	1847V	
1955-62	6	American, Classic, Custom, Rambler, Super Six	55, 56, 57		Delco	1167	
1960-62	6	American, Classic, Custom, Rambler, Super Six	55, 56, 86		Autolite	1569	
1963-74	6	All models	79		Delco	1162A	91162A
1958-70	8	Rebel	19, 72, 79, 88		Delco	1181	91181
1958-74	8	Ambassador	19, 72, 79, 88		Delco	1181	91181
1961-66	8	Classic	19, 72, 79, 88		Delco	1181	91181
1965-67	8	Marlin	19, 72, 79, 88		Delco	1181	91181
1968-74	8	AMX, Javelin	19, 72, 79, 88		Delco	1181	91181
1970-74	8	Hornet, Matador	19, 72, 79v		Delco	1181	91181
1978-79	8	All models	2, 17, 79		Motorcraft	FO-181	9FO-181
<b>AMERICAN AUSTIN / BANTAM</b>							
1930-40	4	All models	55, 56		Autolite	1549	
<b>ASTON MARTIN</b>							
1951-58	6	DB2, DB3	13, 57	DVXH6A	Lucas	LU-168LS	
1958-59	6	DB MKIII Saloon	13, 57	DVXH6A	Lucas	LU-168LS	
1960-64	6	DB4, DB5		DMBZ6A	Lucas	LU-165	
1965-73	6	Volante	57	25D6	Lucas	LU-162A	
1965-77	6	DB6, DBS	57	25D6	Lucas	LU-162A	
1969-73	8	DBS	32	35D8	Lucas	LU-185	
<b>AUBURN</b>							
1935-36	8	90, 100LS	56	IGP-4002	Autolite	1585A	



MR-LS1

### FOOTNOTES

- |  |   |
|--|---|
| 2 Factory electronic ignition                                      | 57 Also available in 12-volt positive ground, add P12 to part number      |
| 13 Lobe sensor module  | 72 Fits single point and dual point distributors                          |
| 17 Small cap distributor   | 79 Ignitor II applications can not be used with solid core ignition wires |
| 19 Mechanical advance at top of shaft                              | 86 Requires modification to distributor                                   |
| 32 Vacuum retard distributor                                       | 88 Ignitor III kit available see page 4 for details                       |
| 34 Non vacuum advance distributor                                  |   |
| 55 Also available in 6-volt negative ground, add N6 to part number |   |
| 56 Also available in 6-volt positive ground, add P6 to part number |   |

New applications appear in red

Year	Cyl	Model	Footnotes	Dist No.	Dist Make	IGNITOR	Ignitor® II
<b>AUDI</b>							
1970-72	4	90, 100LS		231167011, 045	Bosch	1847V	
1972	4	Super 90		231176014	Bosch	1847V	
1973-74	4	Fox, 80LS			Bosch	1847V	
1970-75	4	100, GL, LS			Bosch	1847V	
1976-77	4	100, 100LS (1900cc)			Bosch	1847V	
1975-79	4	Fox 1600cc		231176057	Bosch	1847V	
1979-80	4	4000	1	231176057	Bosch	1847V	
<b>AUSTIN</b>							
1952-56	4	All models	13, 57, 70	DM2P4	Lucas	LU-241LS	
1957-62	4	All models	57, 71	DM2P4	Lucas	LU-149	
1963-74	4	All models	57	25D4	Lucas	LU-142A	
1975-79	4	All models	2, 79	45DE4	Lucas	LU-141	9LU-141
1949-54	6	Sheerline		DVX6A	Lucas	LU-168LS	
1968-71	6	All models	57	25D6	Lucas	LU-162A	
<b>AUSTIN-HEALEY</b>							
1954-56	4	100 early distributor	13, 57, 70	DM2P4	Lucas	LU-241LS	
1954-56	4	100 late distributor	57, 71	DM2P4	Lucas	LU-149	
1958-61	4	Sprite	57, 71	DM2P4	Lucas	LU-149	
1958-71	4	Sprite	57	25D4	Lucas	LU-142A	
1958-71	4	Sprite	34, 57	23D4	Lucas	LU-148	
1957-63	6	All models	57	DM6	Lucas	LU-165	
1963-68	6	All models	57	25D6	Lucas	LU-162A	
<b>BENTLEY</b>							
1962-68	8	T Series, Continental	57	20D8	Lucas	RR-181	
1973	8	T Series, Continental		35D8	Lucas	LU-185	
<b>BMW</b>							
1969-70	4	2000	3		Bosch	1847V	
1969-72	4	2002	3		Bosch	1847V	
1972-73	4	2002 Tii			Bosch	1847V	
1972-73	4	2002		231180008	Bosch	1843	
1972-73	4	2002		231180003	Bosch	1847V	
1974	4	2002 Tii, 2002			Bosch	1843	
1975-76	4	2002			Bosch	1847V	
1977-79	4	320i			Bosch	1847V	
1974	6	3.0 CSi	79		Bosch	1868	91868
1975	6	530i	79		Bosch	1868	91868
1975-76	6	3.0 Si, CSi	1, 79		Bosch	1868	91868
1976-78	6	530i	1, 79		Bosch	1868	91868
1977-78	6	630 CSi	1, 79		Bosch	1868	91868
<b>BRISTOL</b>							
1949-61	6	All models	13, 57	DX6A	Lucas	LU-168LS	
<b>BUICK</b>							
1962-67	6	All V-6 models	19, 43		Delco	1165	
1968-74	6	All models	79		Delco	1162A	91162A
1931-56	8	All models	16, 55		Delco	1183	
1931-56	8	All models	13, 16		Delco	1185LS	
1957-74	8	All models	19, 72, 79, 88		Delco	1181	91181
1957-74	8	All models	13, 18, 19, 88		Delco	1181LS	
<b>CADILLAC</b>							
1932-55	8	All models	16, 55		Delco	1183	
1956-74	8	All models	13, 18, 19, 88		Delco	1181LS	
1956-74	8	All models	19, 79, 88		Delco	1181	91181
<b>CHECKER CAB</b>							
1964-74	6	230-250 cid. engine	79		Delco	1162A	91162A
1935-39	8	Y	56	IGT-4003	Autolite	1587	
1964-74	8	All models	19, 79, 88		Delco	1181	91181
<b>CHEVROLET</b>							
1974-75	4	LUV Pickup			Hitachi	1741	
1962-74	4	All models	79		Delco	1144A	91144A
1941-53	6	216, 235, 261 cid engine	36, 55, 56, 57		Delco	1167	
1954-62	6	216, 235, 261 cid engine	36, 55, 56, 57		Delco	1168	
1953	6	Corvette	56	1112314	Delco	1161	
1963-74	6	All models	79		Delco	1162A	91162A
1956-61	8	All models	16, 55		Delco	1183	
1956-61	8	All models	10, 16, 55		Delco	1183	
1957-74	8	All models	19, 79, 88		Delco	1181	91181
1957-74	8	All models	13, 19, 88		Delco	1181LS	
<b>CORD</b>							
1936-67	8		56	IGP-4006	Autolite	1585A	



Year	Cyl	Model	Footnotes	Dist No.	Dist Make	IGNITOR	Ignitor II
<b>CHRYSLER</b>							
1984-88	4	Colt non turbo	2, 79		Mitsubishi	1944	91944
1985-89	4	2600cc Pickup	2, 79		Mitsubishi	1944	91944
1987-89	4	Raider	2, 79		Mitsubishi	1944	91944
1978-83	6	All models	2, 15, 79		Chrysler	CH-161	9CH-161
1935-42	8	All models	56	IGT-4001	Autolite	1587	
1946-48	8	All models	56	IGT-4002	Autolite	1587	
1949-50	8	All models	56	IAR-4101	Autolite	1587	
1951-58	8	331cid engines	10, 56	IBK, IAZ Series	Autolite	1383	
1959-71	8	383, 413, 426, 440 cid. engine (Hemi Included)	10		Auto/Prestolite	1382	
1968-73	8	340 six pack engine			Prestolite	1384	
1962-75	8	All models	8, 79, 88		Chrysler	1381A	91381A
1972-83	8	All models	2, 15, 79		Chrysler	CH-181	9CH-181
<b>CITROËN</b>							
1952-55	4	All models	57, 71	DM2P4	Lucas	LU-149	
1957-65	4	ID, DS	55, 35	A147	SEV	SV-142	
1965-66	4	ID19 80cv		4944, 4175	Ducellier	EP-141	
1965-67	4	DS19 90cv		4169, 4177A	Ducellier	EP-141	
1966-70	4	ID16 90cv		41401, 4188	Ducellier	EP-141	
1965-72	4	DS21 109cv		4155	Ducellier	EP-141	
1965-72	4	Pallas 105cv		4176	Ducellier	EP-141	
1968-72	4	DS21		A253	SEV	SV-141	
1933-57	4	Traction Avant 11			Ducellier	EP-141	
1938	6	15/6	55		SEV	SV-161	
<b>DAIMLER</b>							
1969-71	6	All 4.2 models	57	22D6	Lucas	LU-166A	
1960-64	8	SP250	57	20D8	Lucas	RR-181	
<b>DESOTO</b>							
1952-55	8	All models	10, 56	IBK, IAZ Series	Autolite	1383	
<b>DODGE</b>							
1980	4	Colt, Challenger with 1400,1600 engine	1		Hitachi	1741	
1981	4	Colt	5		Hitachi	1741	
1985-89	4	2.6L Raider, Ram Pickup	2, 79		Mitsubishi	1944	91944
1960-72	6	All models	79		Chrysler	1361A	91361A
1973-83	6	All models	2, 15, 79		Chrysler	CH-161	9CH-161
1953-55	8	All models	10, 56	IBK, IAZ Series	Autolite	1383	
1957-58	8	All models	10, 56	IBK, IAZ Series	Autolite	1383	
1959-71	8	383, 413, 426, 440 cid. engine (Hemi Included)	10		Auto/Prestolite	1382	
1968-73	8	340 six pack engine			Prestolite	1384	
1960-72	8	All models	8, 79, 88		Chrysler	1381A	91381A
1972-83	8	All models	2, 15, 79		Chrysler	CH-181	9CH-181
<b>DODGE BROTHERS</b>							
1919-26	4	All models	56, 57	10004	N.E. Electric	NE-141	
1927-30	6	All models	56, 57	10836, 10846	N.E. Electric	NE-161	
<b>FERRARI</b>							
1966-74	6	Dino 246GT, GTS	64, 79, 85	S125	Marelli	MR-161	9MR-161
1967-69	6	Dino 206	64, 79, 85	S125	Marelli	MR-161	9MR-161
1975	8	308	79, 85	S159B	Marelli	MR-182	9MR-182
1977	8	308 GTB	14, 59, 63, 79, 85	S127	Marelli	MR-181	9MR-181
1970-72	12	365 GT	60, 61, 62, 79, 85	S138	Marelli	MR-1121	9MR-1121
1966-68	12	330 GTC	60, 61, 64, 79, 85	S85A	Marelli	MR-1122	9MR-1122
<b>FIAT</b>							
1955-75	2	500	35	S76	Marelli	MR-122	
1972-88	2	126	35	S152	Marelli	MR-122	
1960-65	4	150D Cabrioler 118H, K, Ghia Coupe	13	S91	Marelli	MR-LS2	
1964-69	4	118Sb, 1600S Cabriolet	13	S106	Marelli	MR-LS2	
1967-68	4	1300 Berlina, 1500 Berlina, 1500L, Cabriolet, Familia	13	S91, S108	Marelli	MR-LS2	
1969-77	4	125 Berlina,	13	S147	Marelli	MR-LS1	



1181

### FOOTNOTES

- |   |  |   |
|---|--|---|
| <ul style="list-style-type: none"> <li>1 Excluding California models</li> <li>2 Factory electronic ignition</li> <li>3 Excluding Bosch distributor number 0231115045</li> <li>5 Canadian models only</li> <li>8 Single point distributor</li> <li>10 Dual point distributor</li> <li>13 Lobe sensor module</li> <li>14 European models only</li> <li>15 Excluding lean burn computer controlled engines</li> <li>16 Mechanical advance under breaker plate</li> <li>18 Excluding 215 and 300 cid. engine</li> </ul> | <ul style="list-style-type: none"> <li>19 Mechanical advance at top of shaft</li> <li>34 Non vacuum advance distributor</li> <li>35 Special keeper no. MR-122K required for distributors without distributor cap</li> <li>36 Excluding distributor number 1112314</li> <li>43 Odd fire engine</li> <li>55 Also available in 6-volt negative ground, add N6 to part number</li> <li>56 Also available in 6-volt positive ground, add P6 to part number</li> <li>57 Also available in 12-volt positive ground, add P12 to part number</li> <li>59 Single distributor applications</li> </ul> | <ul style="list-style-type: none"> <li>60 Dual distributor applications</li> <li>61 Kit contains one module for each distributor</li> <li>62 With six lobe point cam</li> <li>63 With four lobe point cam</li> <li>64 With three lobe point cam</li> <li>70 Early DM2 distributor</li> <li>71 Late DM2 distributor</li> <li>72 Fits single point and dual point distributors</li> <li>79 Ignitor II applications can not be used with solid core ignition wires</li> <li>85 Point cam felt bracket removal required</li> <li>88 Ignitor III kit available see page 4 for details</li> </ul> |
|---|--|---|

New applications appear in red

ELECTRONIC IGNITION CONVERSIONS

Year	Cyl	Model	Footnotes	Dist No.	Dist Make	IGNITOR®	Ignitor® II
<b>FIAT (CONTINUED)</b>							
1970-77	4	1300, 1500, Berlina, Cabriolet, Familia	13	S91	Marelli	MR-LS2	
1970-77	4	1500L, 1600S	13	S106, S108A	Marelli	MR-LS2	
1971-77	4	124	13	S134, S144, S147	Marelli	MR-LS1	
1971-77	4	125 Special	13	S134, S147	Marelli	MR-LS1	
1971-77	4	127 Berlina	13	S145, S146	Marelli	MR-LS1	
1972-77	4	132 Berlina Special, GL	13	S144	Marelli	MR-LS1	
1972-77	4	132 Berlina	13	S134, S144, S147	Marelli	MR-LS1	
1973-77	4	131	13	S144, S147	Marelli	MR-LS1	
1974	4	X 1/9	13	S153	Marelli	MR-LS1	
1975-77	4	132 GL, GLS	13	S134, S137, S144, S147	Marelli	MR-LS1	
1975-78	4	241 T, 242	13	S147	Marelli	MR-LS1	
1976-78	4	238B, Bi, 850 T	13	S147, S146	Marelli	MR-LS1	
1965-69	6	1800B Berlina, 2300 Berlina Lusso, Familia	13	S96	Marelli	MR-LS2	
<b>FORD</b>							
1941-42	4	All models	23, 56		Ford	1247	
1941-42	4	All models	23, 31, 56		Ford	1247XT	
1971-73	4	1600cc engine	79		Motorcraft	1241	91241
1971-74	4	2000cc engine			Bosch	1847V	
1974	4	2300cc engine	79		Motorcraft	1243A	91243A
1949-74	6	All models (excluding V-6 engine)	69, 79		Motorcraft	1261	91261
1963-67	6	All models (excluding V-6 engine)	55, 56, 68, 79		Holley	1266	91266
1974	6	Mustang	79		Bosch	1867A	91867A
1949-53	8	Flat Head engine	55, 56, 57, 79		Motorcraft	1283	91283
1954-56	8	Y block engine	55, 56, 79		Motorcraft	1282	91282
1957-74	8	All models	8, 79, 88		Motorcraft	1281	91281
1960-72	8	All models	10, 34, 79, 88		Motorcraft	1284	91284
1960-72	8	All models	10, 33, 79, 88		Motorcraft	1281DV	91281DV
1974-76	8	All models	2, 17, 79		Motorcraft	FO-181	9FO-181
1977-83	8	All models	2, 20, 79		Motorcraft	FO-182	9FO-182
All	8	Flat Head engine		40068F	Lucas	LU-186	
<b>FORD TRUCKS</b>							
1941-42	4	All models	23, 56		Ford	1247	
1941-42	4	All models	23, 31, 56		Ford	1247XT	
1972-73	4	Courier 1800cc	8		Hitachi	1741	
1963-67	6	All models	55, 56, 68, 79		Holley	1266	91266
1949-75	6	All models	69, 79		Motorcraft	1261	91261
1949-53	8	All models	54, 55, 56, 79		Motorcraft	1282	91282
1949-53	8	All models 239 cid.	55, 56, 57, 79		Motorcraft	1283	91283
1954-56	8	Ford Y block engine	55, 56, 79		Motorcraft	1282	91282
1957-74	8	All models	8, 79, 88		Motorcraft	1281	91281
1974-76	8	All models	2, 17, 79		Motorcraft	FO-181	9FO-181
1977-83	8	All models	2, 20, 79		Motorcraft	FO-182	9FO-182
<b>FORD (EUROPE)</b>							
1956-63	4	Consul	57	25D4	Lucas	LU-142A	
1964-66	4	Cortina Lotus	34, 57	23D4	Lucas	LU-148	
1967	4	Taurus 12M, 15M			Bosch	1847V	
1956-67	4	Anglia	57	25D4	Lucas	LU-142A	
1967-68	4	Taurus 17M, 20M			Bosch	1847V	
1967-69	4	Corsair	79		Motorcraft	1243A	91243A
1964-70	4	Cortina	57	25D4	Lucas	LU-142A	
1966-72	4	Zephyr	79		Motorcraft	1243A	91243A
1968-74	4	Escort 1600cc		25D4	Lucas	LU-142A	
1966-79	4	Capri	79		Motorcraft	1243A	91243A
1966-79	4	Escort	79		Motorcraft	1243A	91243A
1972-79	4	Cortina	79		Motorcraft	1243A	91243A
1972-79	4	Consul	79		Motorcraft	1243A	91243A
1975-79	4	Escort			Bosch	1847V	
1978-80	4	Cortina 2300			Bosch	1847V	
All	4	All models	34, 79	43D4	Lucas	LU-143	9LU-143
<b>GMC TRUCK</b>							
1964-66	4	All Models	79		Delco	1144A	91144A
1939-62	6	All Models	16, 28, 55, 56, 57		Delco	1167	
1960-65	6	All Models	19, 55		Delco	1164	
1964-74	6	All Models	16, 27, 79		Delco	1162A	91162A
1955-56	8	All Models	16, 55		Delco	1183	
1957-74	8	All Models	79, 88		Delco	1181	91181
<b>HILLMAN</b>							
1955-56	4	All models	13, 57, 70	DM2P4	Lucas	LU-241LS	
1957-61	4	All models	57, 71	DM2P4	Lucas	LU-149	
1962-73	4	All models	57	25D4	Lucas	LU-142A	
1974-79	4	All models	79	45D4	Lucas	LU-144	9LU-144

Year	Cyl	Model	Footnotes	Dist No.	Dist Make	IGNITOR	Ignitor II
<b>HONDA</b>							
1973-79	4	Civic			Hitachi	1741	
1975-79	4	Accord, CVCC			Hitachi	1741	
1977-79	4	Prelude			Hitachi	1741	
1968-70	4	800	14	29100-093	Denso	1647	
<b>HUDSON</b>							
1937-47	6	All models	55, 56	IGW Series	Autolite	1568	
1950-55	6	All models	56	IAT Series	Autolite	1362	
1935-36	8	All models	56	IGP-4001	Autolite	1585A	
1937-42	8	All models	56	IGP-4008	Autolite	1585A	
1946-47	8	All models	56	IGP-4008	Autolite	1585A	
1948-52	8	All models	56	IGT-4204	Autolite	1587	
<b>HUMBER</b>							
1953-56	4	Hawk	13, 57, 70	DM2P4	Lucas	LU-241LS	
1961-62	4	Hawk	57, 71	DM2P4	Lucas	LU-149	
1962-70	4	Hawk, Sceptre	57	25D4	Lucas	LU-142A	
1954-62	6	Super Snipe	57		Lucas	LU-165	
1962-67	6	Imperial, Super Snipe	57		Lucas	LU-162A	
<b>HUPMOBILE</b>							
1928-40	6	All models	55, 56		Autolite	1568	
1935-39	8	All models	56	IGP Series	Autolite	1585A	
<b>HYUNDAI</b>							
1984-86	4	Pony, Stellar	5		Hitachi	1741	
1986-94	4	1.5L Excel	4, 79		Mitsubishi	1944	91944
<b>IHC TRUCK</b>							
1957-64	4	All models	57		Lucas	LU-142A	
1961-80	4	All models	19		Delco	1141	
1967-72	4	All models	39		Holley	HO-141	
1967-72	4	All models	40, 83		Holley	HO-142	
1972-74	4	All models			Prestolite	1441A	
1974-79	4	All models	2		Prestolite	1441A	
1974-79	4	All models	2, 22, 79		Holley	HO-143	9HO-143
1946-69	6	All models			Delco	1167	
1967-80	6	All models	79		Delco	1162A	91162A
1959-64	8	266, 304, 345 cid. engine	19, 72, 79, 88		Delco	1181	91181
1964-83	8	All models	22, 33, 79		Holley	1481	91481
1964-83	8	All models	22, 33, 83, 79		Holley	HO-182	9HO-182
1964-70	8	All models	24, 79		Holley	1482	91482
1964-83	8	All models	22		Prestolite	1483	
1972-81	8	All models with Holley Gold Box Ignition	2, 22, 88		Holley	HO-181	
1974-83	8	All models	2, 38		Prestolite	1483A	
1974-83	8	404, 446 cid. engines	38		Prestolite	1484A	
1974-83	8	All models	2	IDN-4007	Prestolite	1485A	
<b>JAGUAR</b>							
1949-57	6	All Models	13, 57	DVX6A	Lucas	LU-168LS	
1956-63	6	All Models	57	DMBZ6A	Lucas	LU-165	
1964-74	6	All Models		22D6	Lucas	LU-166A	
1968-69	6	All Models	57	25D6	Lucas	LU-162A	
1975-76	6	XJ6	2	45DE6	Lucas	LU-161	
1977-84	6	XJ6	2	45DM6	Lucas	LU-167	
1971-81	12	XJ12, XJS, E-Type	2	36DE12	Lucas	LU-1122	
1982-84	12	XJ12HE, XJSHE	2	36DM12	Lucas	LU-1121	
<b>JEEP</b>							
1960-71	4	All Models	55, 79	IAY-4401	Prestolite	1548	91548
1959-60	4	All Models	79	1110225	Delco	1144A	91144A
1940-59	4	All Models	55	IAD-4008	Auto-Lite	2541	
1970-74	6	All Models	79		Delco	1162A	91162A
1967-69	6	All Models	19, 43	1110376	Delco	1165	
1966-69	6	All Models		1110444	Delco	1162A	
1963-65	6	All Models		IAT-4416	Auto/Prestolite	2561	



### FOOTNOTES

- |   |  |  |
|---|--|--|
| <ul style="list-style-type: none"> <li>2 Factory electronic ignition</li> <li>4 Non fuel injection models</li> <li>5 Canadian models only</li> <li>8 Single point distributor</li> <li>10 Dual point distributor</li> <li>14 European models only</li> <li>13 Lobe sensor module</li> <li>16 Mechanical advance under breaker plate</li> <li>17 Small cap distributor</li> <li>19 Mechanical advance at top of shaft</li> <li>20 Large cap distributor</li> <li>22 Clockwise rotation</li> <li>24 Counter clockwise rotation</li> </ul> | <ul style="list-style-type: none"> <li>27 Screw down cap</li> <li>28 Clip down cap</li> <li>31 Remote mount coil conversion kit included</li> <li>33 Vacuum advance distributor</li> <li>34 Non vacuum advance distributor</li> <li>38 Excluding distributor number IDN-4007</li> <li>39 With "curved" point set</li> <li>40 With "straight" point set</li> <li>43 Odd fire engine</li> <li>54 Excluding 239 cid. engines</li> <li>55 Also available in 6-volt negative ground, add N6 to part number</li> </ul> | <ul style="list-style-type: none"> <li>56 Also available in 6-volt positive ground, add P6 to part number</li> <li>57 Also available in 12-volt positive ground, add P12 to part number</li> <li>68 Overhead view of motorcraft distributor Shaft</li> <li>69 Overhead view of Holley distributor Shaft</li> <li>70 Early DM2 distributor</li> <li>71 Late DM2 distributor</li> <li>72 Fits single point and dual point distributors</li> <li>79 Ignitor II applications can not be used with solid core ignition wires</li> <li>83 With plastic sliding point plate</li> <li>88 Ignitor III kit available see page 4 for details</li> </ul> |
|---|--|--|

New applications appear in red

Year	Cyl	Model	Footnotes	Dist No.	Dist Make	IGNITOR	Ignitor® II
<b>JEEP (CONTINUED)</b>							
1960-64	6	All Models		IAT-4404	Auto/Prestolite	2561	
1966-74	8	All Models	19, 72, 79, 88		Delco	1181	91181
1977-92	8	All Models	2, 17, 79		Motorcraft	FO-181	9FO-181
<b>LAMBORGHINI</b>							
1964-68	12	350, 400	10, 24, 60, 61, 64, 85	S85B, C, CA	Marelli	MR-1123	
1968-78	12	Espada	10, 24, 60, 61, 64, 85	S85B, C, CA	Marelli	MR-1123	
1970-76	12	Jarama	10, 24, 60, 61, 64, 85	S85B, C, CA	Marelli	MR-1123	
1981-88	12	Jalpa	10, 24, 60, 61, 64, 85	S85B, C, CA	Marelli	MR-1123	
1974-89	12	Countach	10, 24, 60, 61, 64, 85	S85B, C, CA	Marelli	MR-1123	
<b>LANCIA</b>							
1964-69	4	Flavia Coupe	13	S139	Marelli	MR-LS1	
1964-69	4	Berlina	13	S105	Marelli	MR-LS2	
1965-70	4	Flavia, Fulvia GT, Rallye, Sport, Sport Coupe	13	S102, S105	Marelli	MR-LS2	
<b>LASALLE</b>							
1940-42	8	All models			Delco	1183	
<b>LINCOLN</b>							
1949	8	All models	56		Autolite	1587	
1950-51	8	All models with Flathead engine	55, 56, 57, 79		Ford	1283	91283
1952-56	8	All models with Y Block engine	55, 56, 79		Ford	1282	91282
1957-73	8	All models	79, 88		Motorcraft	1281	91281
1974-76	8	All models	2, 17, 79		Motorcraft	FO-181	9FO-181
1977-83	8	All models	2, 20, 79		Motorcraft	FO-182	9FO-182
1932-39	12			IGM-4002	Autolite	15121	
<b>LOTUS</b>							
1964-73	4	Elan	34, 57	23D4	Lucas	LU-148	
1967-73	4	Seven	57	25D4	Lucas	LU-142A	
1970-75	4	Europra	34	23D4	Lucas	LU-148	
1974-79	4	Eclat, Elite, Esprit		25D4	Lucas	LU-142A	
1977-79	4	Eclat, Elite, Esprit	79	43D4	Lucas	LU-143	9LU-143
<b>MAZDA (NON ROTARY)</b>							
1970-71	4	1200, 1500			Hitachi	1741	
1970-74	4	1800			Hitachi	1741	
1971-72	4	616 (1600cc) 808	9		Hitachi	1741	
1972-73	4	1600cc	7		Hitachi	1741	
1972-74	4	B1600, 616, 618			Hitachi	1741	
1972	4	618 (1800cc)	6		Hitachi	1741	
1973	4	618 (1800cc)			Hitachi	1741	
1987-88	4	B2600	79		Mitsubishi	1944	91944
<b>MASERATI</b>							
1966-76	8			231127004	Bosch	1888	
<b>MERCEDES</b>							
1966-67	4	200		231170138	Bosch	1847V	
1966-67	4	200		231115052	Bosch	2843	
1972-73	4	220, 280			Bosch	1847V	
1974-77	4	230, 240			Bosch	1847V	
1958-62	6	300 Roadster	10, 64	ZV / PCS 6 R 1T	Bosch	2866	
1961-62	6	300D	55	231116040	Bosch	1864A	
1962-67	6	300SE	10, 64	231141002 (ZV/PB 6R1T)	Bosch	2865	
1965	6	220SE	55	231116040	Bosch	1864A	
1966-67	6	230SL	55	231116051	Bosch	1864LA	
1966-67	6	230, S	55	231116048	Bosch	1864A	
1967	6	250SE		231116051	Bosch	1864LA	
1968-69	6	280SE, SL, 300SEL		231116051	Bosch	1864LA	
1970	6	280SE, SEL		231116061	Bosch	1863	
1970	6	250C, 280S	79		Bosch	1867A	91867A
1973-74	6	280		231310002	Bosch	2861	
1975-76	6	280	79	231311001	Bosch	1868	91868
1953-54	8	300SL	10, 63	ZV/LBUR 8 R2	Bosch	1889	
1972	8	280SE, SEL, 300SEC, 350SL	79		Bosch	1885	91885
<b>MERCURY</b>							
1971-72	4	All models 98 cid. engine (1600cc)	79		Motorcraft	1241	91241
1971-74	4	All models 122 cid. engine (2000cc)			Bosch	1847V	
1974	4	All models 140 cid. engine (2300cc)	79		Motorcraft	1243A	91243A
1958-74	6	All models	79		Motorcraft	1261	91261
1972-74	6	All models	79		Bosch	1867A	91867A
1949-53	8	All models flathead	55, 56, 57, 79		Motorcraft	1283	91283
1954-56	8	All models Y block	55, 56, 79		Motorcraft	1282	91282
1960-73	8	All models	10, 34, 79, 88		Motorcraft	1284	91284
1960-73	8	All models	10, 33, 79, 88		Motorcraft	1281DV	91281DV
1957-74	8	All models	8, 79, 88		Motorcraft	1281	91281
1974-76	8	All models	2, 17, 79		Motorcraft	FO-181	9FO-181
1977-83	8	All models	2, 20, 79		Motorcraft	FO-182	9FO-182

Year	Cyl	Model	Footnotes	Dist No.	Dist Make	IGNITOR	Ignitor® II
<b>METROPOLITAN</b>							
1954-55	4	540	13, 57, 70	DM2P4	Lucas	LU-241LS	
1955-64	4	560, 1500	57, 71	DM2P4	Lucas	LU-149	
<b>MG</b>							
1946-52	4	TC, TD	41, 56, 57	DKY4A	Lucas	LU-146	
1946-52	4	TC, TD	37, 42, 56, 57	DKY4A	Lucas	LU-146M	
1956-62	4	MGA	57, 71	DM2P4	Lucas	LU-149	
1961-62	4	Midget	57, 71	DM2P4	Lucas	LU-149	
All	4	MGA twin cam	34, 57	23D4	Lucas	LU-148	
1963-74	4	MGB, Midget	57	25D4	Lucas	LU-142A	
1967	4	Midget	34, 57	23D4	Lucas	LU-148	
All	4	All models	79	45D4	Lucas	LU-144	9LU-144
All	4	All models	34, 79	43D4	Lucas	LU-143	9LU-143
1975-76	4	Midget, MGB	2, 79	45DE4	Lucas	LU-141	9LU-141
1977-80	4	Midget, MGB	2, 79	45DM4	Lucas	LU-147	9LU-147
1968-69	6	MGC	57	25D6	Lucas	LU-162A	
1975-76	8	MGB V8	79	35D8	Lucas	LU-181	9LU-181
<b>MINI</b>							
1965-71	4	Cooper S	34	23D4	Lucas	LU-148	
<b>MITSUBISHI</b>							
1984-89	4	2.6L Montero, Pickup	2, 79		Mitsubishi	1944	91944
1985-88	4	1.5L Mirage	2, 79		Mitsubishi	1944	91944
1987-89	4	1.5L Precis	2, 79		Mitsubishi	1944	91944
<b>MORGAN</b>							
1955-59	4	Plus Four	13, 57, 70	DM2P4	Lucas	LU-241LS	
1960-63	4	Plus Four	57, 71	DM2P4	Lucas	LU-149	
1963-66	4	Plus Four	57	25D4	Lucas	LU-142A	
1970-74	8	Plus Eight		35D8	Lucas	LU-181	
<b>MORRIS</b>							
1957-62	4	Minor 1000	57, 71	DM2P4	Lucas	LU-149	
1963-74	4	All Models		25D4	Lucas	LU-142A	
1974-75	4	All Models	79	45D4	Lucas	LU-144	9LU-144
<b>NASH</b>							
1951-55	6	All Models	55, 56, 57		Delco	1167	
1942	8		56	IGT-4202	Autolite	1587	
<b>NISSAN / DATSUN</b>							
1977	4	F10, 200SX, B-210, 620 Truck, 710			Hitachi	1741	
1966-67	4	411			Hitachi	1741	
1966-69	4	520 Truck, 521 Truck			Hitachi	1741	
1968-69	4	510	8		Hitachi	1741	
1967-70	4	311	8		Hitachi	1741	
1971-73	4	B-110			Hitachi	1741	
1974-76	4	B-210, 610, 620 Truck, 710			Hitachi	1741	
1979-80	4	210 A12 engine			Hitachi	1741	
1970-73	6	240Z	8		Hitachi	1761	
<b>OLDSMOBILE</b>							
1967-73	4	All models			Bosch	1847V	
1964-65	6	All models V-6	19, 43		Delco	1165	
1966-74	6	All models	16, 79		Delco	1162A	91162A
1940-55	8	All models	16, 55		Delco	1183	
1940-55	8	All models	13, 16		Delco	1187LS	
1956-74	8	All models	19, 72, 79, 88		Delco	1181	91181
1956-74	8	All models	13, 18, 19, 88		Delco	1181LS	



**LU-142A**

### FOOTNOTES

- |   |   |  |
|---|---|--|
| <ul style="list-style-type: none"> <li>2 Factory electronic ignition</li> <li>6 California models only</li> <li>7 Manual trans only</li> <li>8 Single point distributor</li> <li>9 Excluding California model with auto trans</li> <li>10 Dual point distributor</li> <li>13 Lobe sensor module</li> <li>16 Mechanical advance under breaker plate</li> <li>17 Small cap distributor</li> <li>18 Excluding 215 and 300 cid. engine</li> <li>19 Mechanical advance at top of shaft</li> <li>20 Large cap distributor</li> <li>24 Counter clockwise rotation</li> </ul> | <ul style="list-style-type: none"> <li>33 Vacuum advance distributor</li> <li>34 Non vacuum advance distributor</li> <li>37 With asymmetric point cam</li> <li>41 Distributor with part number suffix from E-Z</li> <li>42 Distributor with part number suffix from A-D</li> <li>55 Also available in 6-volt negative ground, add N6 to part number</li> <li>56 Also available in 6-volt positive ground, add P6 to part number</li> <li>57 Also available in 12-volt positive ground, add P12 to part number</li> <li>60 Dual distributor applications</li> <li>61 Kit contains one module for each distributor</li> </ul> | <ul style="list-style-type: none"> <li>63 With four lobe point cam</li> <li>64 With three lobe point cam</li> <li>69 Overhead view of Holley distributor Shaft</li> <li>70 Early DM2 distributor</li> <li>71 Late DM2 distributor</li> <li>72 Fits single point and dual point distributors</li> <li>79 Ignitor II applications can not be used with solid core ignition wires</li> <li>85 Point cam felt bracket removal required</li> <li>88 Ignitor III kit available see page 4 for details</li> </ul> |
|---|---|--|

New applications appear in red

Year	Cyl	Model	Footnotes	Dist No.	Dist Make	IGNITOR	Ignitor® II
<b>OPEL</b>							
1966-67	4	Kadett			Bosch	1847V	
1967-72	4	Kadett 1.1 Litre			Bosch	1847V	
1968-74	4	GT 1900, Kadett 1.9 Litre			Bosch	1847V	
1968	4	Kadett 1.5 Litre			Bosch	1847V	
1972-75	4	Manta			Bosch	1847V	
1975	4	1900			Bosch	1847V	
<b>PACKARD</b>							
1937	8	All models	56	IGT-4004	Aulolite	1587	
1940-50	8	356 cid. engine	56	IGT-4203	Aulolite	1587	
1940-42	8	All models	56	IGP Series	Aulolite	1585A	
1946-54	8	All models	56	IGP Series	Aulolite	1585A	
1955	8	Custom Clipper, 5560, 5580	16, 55	1110854	Delco	1183	
<b>PANTERA</b>							
1971-72	8	All models	5, 79, 88		Motorcraft	1281	91281
1972-74	8	All models	10, 79, 88		Motorcraft	1284	91284
<b>PEUGEOT</b>							
1957-78	4	All Models			Ducellier	EP-141	
1957-78	4	All Models			SEV	SV-142	
<b>PLYMOUTH</b>							
1980	4	1400cc, 1600cc	1		Hitachi	1741	
1981	4	1400cc, 1600cc	5		Hitachi	1741	
1976-79	4	All models	79		Mitsubishi	1942	91942
1939	6	All models	55, 56, 86	IGS-4204	Aulolite	1569	
1960-72	6	All models	8, 79		Chrysler	1361A	91361A
1973-81	6	All models	2, 15, 79		Chrysler	CH-161	9CH-161
1955-58	8	All models	10, 56	IBK, IAZ Series	Aulolite	1383	
1959-71	8	383, 413, 426, 440 cid. engine (Hemi Included)	10		Auto/Prestolite	1382	
1959-72	8	All models	8, 79, 88		Chrysler	1381A	91381A
1968-73	8	340 six pack engine			Prestolite	1384	
1972-81	8	All models	2, 15, 79		Chrysler	CH-181	9CH-181
<b>PONTIAC</b>							
1962-63	4	All models	16, 79		Delco	1144A	91144A
1962-74	6	All models	79		Delco	1162A	91162A
1955-56	8	All models	16, 55		Delco	1183	
1955-56	8	All models	13, 16		Delco	1187LS	
1957-74	8	All models	19, 72, 79, 88		Delco	1181	91181
1957-74	8	All models	13, 18, 19, 88		Delco	1181LS	
<b>PORSCHE</b>							
1976	4	912E			Bosch	1847V	
1955-66	4	356	55	231129022	Bosch	1844	
1955-66	4	356	55	231129031	Bosch	2847	
1966-67	4	912	55	231129022	Bosch	1844	
1966-67	4	912	55	231129031	Bosch	2847	
1968-69	4	912			Bosch	1843	
1970-76	4	914			Bosch	1847V	
1976-77	4	924		231170202, 176064	Bosch	1847V	
1968	6	911L, T			Bosch	1863	
1973	6	911, E, S, T models from to May of 1973	79		Bosch	1867A	91867A
1974-77	6	911, 911S, Carrera	79		Bosch	1867A	91867A
1965-67	6	911, S, T			Bosch	1866	
1969-71	6	911, E, S, T			Bosch	2862	
1969-71	6	911, E, S, T	13	S112AX	Marelli	MR-LS1	
1972-73	6	911, E, S, T models up to May of 1973			Bosch	1863	
1971	6	914-6		231159008	Bosch	2862	
<b>RELIANT</b>							
1962-63	4	Sabre	57, 71	DM2P4	Lucas	LU-149	
1964-66	4	Sabre	57	25D4	Lucas	LU-142A	
1964-65	6	Sabre, Scimitar	57	25D6	Lucas	LU-162A	
<b>RENAULT</b>							
1952-77	4	All models	55		Bosch	1843	
1952-77	4	All models			Ducellier	EP-141	
1952-77	4	All models	55, 34		SEV	SV-142	
<b>RILEY</b>							
1956-59	4	Pathfinder, L29	57, 71	DM2P4	Lucas	LU-149	
1963-70	4	1.5 Ltr. Elf, Saloon	57	25D4	Lucas	LU-142A	
1967-70	4	Kestrel 1100, 1300	57	25D4	Lucas	LU-142A	
1957-58	6	All models 2.6 Ltr.	57	DM6A	Lucas	LU-165	
<b>ROLLS ROYCE</b>							
1924-25	6	Phantom		D505	Delco	RR-164	
All	6	All	10, 57, 64, 79	PO-6	Delco	RR-162	9RR-162
All	8	All models	57	20D8	Lucas	RR-181	
All	8	All models	63	DR-8N	Delco	RR-182	

Year	Cyl	Model	Footnotes	Dist No.	Dist Make	IGNITOR	Ignitor II
<b>ROVER</b>							
1948-53	4	Landrover	13, 57, 70	DM2P4	Lucas	LU-241LS	
1956-63	4	2 litre	57, 71	DM2P4	Lucas	LU-149	
1963-76	4	2 litre	57	25D4	Lucas	LU-142A	
1977-79	4	2 litre	79	45D4	Lucas	LU-144	9LU-144
1980-89	4	Landrover III		525232A	Ducellier	EP-142	
1952-59	6	90, 105	57	DM6A	Lucas	LU-165	
1955-59	6	75	57	DM6A	Lucas	LU-165	
1959-61	6	3 Litre	57	DM6A	Lucas	LU-165	
1959-62	6	100	57	DM6A	Lucas	LU-165	
1963-79	6	3 Litre	57	25D6	Lucas	LU-162A	
<b>SAAB</b>							
1967-72	4	Sonett V4			Bosch	1847V	
1970-74	4	99E, EA, EMS V4		0231163007, 3025	Bosch	1847V	
1972-74	4	Sonett III, 95, 96 V4			Bosch	1847V	
<b>SIMCA</b>							
1955-71	4	All models			Ducellier	EP-141	
1955-71	4	All models			SEV	SV-141	
<b>SINGER</b>							
1959-61	4	Gazelle	57, 71	DM2P4	Lucas	LU-149	
1962-63	4	Vogue	57	25D4	Lucas	LU-142A	
<b>STUDEBAKER</b>							
1965-66	6	194, 230 cid. engine	79		Delco	1162A	91162A
All	6	All models	55, 56, 86	IAT-4010	Autolite	1569	
1960-61	8	Lark & Regal	19, 72, 57, 88		Delco	1181	91181
1965-66	8	All models	19, 72, 57, 88		Delco	1181	91181
All	8	All models		IBS-4012	Prestolite	1584	
<b>SUBARU</b>							
1975	4	DL, GL			Hitachi	1741	
1969-73	4	1000, 1100, 1300G			Hitachi	1741	
1975-76	4	DL (1400cc)			Hitachi	1741	
<b>SUNBEAM / TALBOT</b>							
1953-54	4	Sunbeam -Talbot 90	13, 57, 70	DM2P4	Lucas	LU-241LS	
1959-61	4	Sunbeam Alpine, Rapier	57, 71	DM2P4	Lucas	LU-149	
1966-68	4	Sunbeam Alpine	57	25D4	Lucas	LU-142A	
1966-73	4	Sunbeam Rapier	57	25D4	Lucas	LU-142A	
<b>TOYOTA</b>							
1971	4	Corolla 1600	79		Nippondenso	1641	91641
1971-76	4	Corolla 1200	79		Nippondenso	1641	91641
1972	4	Corona MK II	79		Nippondenso	1641	91641
1972-74	4	Carina, Celica, Corolla 1600, Corona	79		Nippondenso	1641	91641
1975-76	4	Corolla 1600	8, 79		Nippondenso	1641	91641
1975-77	4	Celica, Corona	79		Nippondenso	1641	91641
1974	6	Landcruiser	1, 79		Nippondenso	1665A	91665A
1970-73	6	Landcruiser	79		Nippondenso	1665A	91665A
<b>TRIUMPH</b>							
1955-62	4	All models	57, 71	DM2P4	Lucas	LU-149	
1962-67	4	All models	57	25D4	Lucas	LU-142A	
All	4	All models	53	D204, D200	Delco	1149A	
All	4	TR7	8, 13, 14, 53	D302-7992715	Delco	MR-LS2	
1975-76	4	Spitfire	2, 79	45DE4	Lucas	LU-141	9LU-141
1977-81	4	Spitfire	2, 79, 80	45DM4	Lucas	LU-147	9LU-147
1975-79	4	TR7	2, 79, 80	47DM4	Lucas	LU-147	9LU-147
1962-75	6	All models		22D6	Lucas	LU-166A	
All	6	All models	53	D204	Delco	1169	
1972	8	Stag	10, 32	35D8	Lucas	LU-185	



1183

### FOOTNOTES

- |   |  |   |
|---|--|---|
| <ul style="list-style-type: none"> <li>1 Excluding California models</li> <li>2 Factory electronic ignition</li> <li>5 Canadian models only</li> <li>8 Single point distributor</li> <li>10 Dual point distributor</li> <li>13 Lobe sensor module</li> <li>14 European models only</li> <li>15 Excluding lean burn computer controlled engines</li> <li>16 Mechanical advance under breaker plate</li> <li>18 Excluding 215 and 300 cid. engine</li> <li>19 Mechanical advance at top of shaft</li> <li>32 Vacuum retard distributor</li> </ul> | <ul style="list-style-type: none"> <li>34 Non vacuum advance distributor</li> <li>53 Distributor marked "made in England"</li> <li>55 Also available in 6-volt negative ground, add N6 to part number</li> <li>56 Also available in 6-volt positive ground, add P6 to part number</li> <li>57 Also available in 12-volt positive ground, add P12 to part number</li> <li>63 With four lobe point cam</li> <li>64 With three lobe point cam</li> <li>70 Early DM2 distributor</li> <li>71 Late DM2 distributor</li> <li>72 Fits single point and dual point distributors</li> </ul> | <ul style="list-style-type: none"> <li>79 Ignitor II applications can not be used with solid core ignition wires</li> <li>80 Excluding distributor number 41812A</li> <li>86 Requires modification to distributor</li> <li>88 Ignitor III kit available see page 4 for details</li> </ul> |
|---|--|---|

New applications appear in red

Year	Cyl	Model	Footnotes	Dist No.	Dist Make	IGNITOR	Ignitor® II
<b>VANDEN PLUS</b>							
1965-68	4	Princess 1100	57	25D4	Lucas	LU-142A	
1968-72	4	Princess 1300	57	25D4	Lucas	LU-142A	
1975	4	Princess 1500	79	45D4	Lucas	LU-144	9LU-144
1961-63	6	3 Litre, 4 Litre		DM6	Lucas	LU-165	
1965-68	6	4 Litre	57	25D6	Lucas	LU-162A	
<b>VAUXHALL</b>							
1977-79	4	1300cc, 1600cc, 2000cc Cavalier			Bosch	1847V	
<b>VOLKSWAGEN</b>							
1960-63	4	Bus (Type II)	20, 55	ZV/PAU 4 R2	Bosch	1845	
1961-64	4	Type I	20, 55	ZV/PAU 4 R2	Bosch	1845	
1964-67	4	Bus (Type II)	55		Bosch	1849	
1965-67	4	Beetle, Karmann Ghia (Type I)	55		Bosch	1849	
1966-67	4	Squareback, Fastback (Type III)	55		Bosch	1849	
1968-73	4	Squareback, Fastback (Type III)			Bosch	1847V	
1968-79	4	Beetle, Karmann Ghia (Type I)			Bosch	1847V	
1971-73	4	411 (Type IV)			Bosch	1847V	
1971-78	4	Bus (Type II)			Bosch	1847V	
1974	4	412 (Type IV)			Bosch	1847V	
1973-75	4	The Thing			Bosch	1847V	
1979	4	Bus (Type II)	1		Bosch	1847V	
1980	4	Dasher, Jetta, Rabbit, Scirocco	1		Bosch	1847V	
1975-79	4	Dasher, Rabbit, Scirocco			Bosch	1847V	
1980-83	4	Vanagon	1		Bosch	1847V	
All	4	Aftermarket 009, 050 distributor	79		Bosch	1847A	91847A
<b>VOLVO</b>							
1966-68	4	122 Series			Bosch	2844	
1966-68	4	1800S			Bosch	2844	
1967-68	4	140 Series			Bosch	2844	
1969-73	4	1800 Series			Bosch	1847V	
1969-74	4	140 Series			Bosch	1847V	
1982-83	4	240 Series	5		Bosch	1847V	
<b>WOLSELEY</b>							
1958-73	4	All Models	57	25D4	Lucas	LU-142A	
1974-75	4	All Models	79	45D4	Lucas	LU-144	9LU-144
1956-63	6	All Models		DM6	Lucas	LU-165	
1964-68	6	6/110	57	25D6	Lucas	LU-162A	

ELECTRONIC IGNITION CONVERSIONS

### AFTERMARKET DISTRIBUTORS

Not getting the performance you expected out of your "brand name" points distributor? Tired of replacing expensive burnt-out optical modules? Then you have come to the right place. Chances are PerTronix makes Ignitor or Ignitor II kit to convert your distributor which will improve reliability and increase your ignition performance.



Description	Cyl	Rotation	Footnotes	IGNITOR	Ignitor® II
<b>ACCEL</b>					
34000 Series	8	CW / CCW	34, 79	AC-181	9AC-181
34000 Series	8	CW / CCW	33, 79	AC-181V	9AC-181V
37000 Series	8	CW / CCW	34	AC-182A	
<b>BOSCH</b>					
009, 050 distributor	4	CW	79	1847A	91847A
<b>MALLORY</b>					
YL711A	3	CCW	34, 64	ML-131	
23, 24, YD, YL series distributors non vacuum	4	CW / CCW	79	ML-141	9ML-141
23, 24, YD, YL series distributors non vacuum	6	CW / CCW	79	ML-161	9ML-161
27 Series	6	CW		ML-162	
25, 26, YD, YL series distributors non vacuum	8	CW / CCW	79, 88	ML-181	9ML-181
27 Series	8	CW / CCW	10, 79	ML-186A	9ML-186A
37, 38, 47, YLU Series Unilite	8	CW / CCW	79	ML-182	9ML-182
YC Series (Rev-pol and Double Life)	8	CW / CCW	63, 79	ML-187A	9ML-187A
YC Series	8	CW / CCW	65	ML-189	
Comp 9000 Series distributors	8	CW / CCW	79	ML-182	9ML-182



**APPLICATIONS BY DISTRIBUTOR PART NUMBER**

We have Ignitor and Ignitor II kits which are made to fit specific distributor types and part numbers. Many of these kits are not tied to a particular vehicle application. If you can't find what you need in the application section of our catalog, use this look up. If its not here, that doesn't mean that we don't have it. If you are interested in a kit for a specific distributor please call (909) 599-5955.

Description	Cyl.	Rotation	Footnotes	IGNITOR	Ignitor II
<b>AUTOLITE / PRESTOLITE</b>					
IAD-4046	2	CCW		1522	
IAM-4001 10A	6	CCW		1567CC	
IAO-4114A IM	6	CW		1567	
IAT-4101 (Chrysler IND 33)	6	CW		1362	
IAU-4005UT, IAU-4007UT	6	CW	66, 67	MV-161	
IAU-4006AUT	4	CCW	66, 67	MV-141	
IAY-4009	6	CW	55, 56, 79	1564	91564
IBM series	8	CW/CCW	28, 34, 50, 79	1581	91581
IBM series	8	CW/CCW	27, 34, 49, 79	1582	91582
IBM-7021	6	CW	79	1563	91563
IBM-7026	4	CW	79	1546	91546
IBT-4101	4	CCW		1544	
IBT-4301D	3	CCW		1531	
IBT-6701A	6	CCW		1565	
IDN-4009	4	CW	2	1441A	
IDU-4407	4	CW/CCW	2	2542	
IDU-7801, IDU-7802	8	CW	2, 79	1589	91589
IGW series	4	CW	56	1545	
IGW-4113, IGW-4146	6	CW	55, 56	1568	
IGW-4199C (fires 180 degrees)	2	CCW		1521	
<b>BOSCH</b>					
0231305091	6	CW	79	1869	91869
0231127005	8	CW		1888	
0231146026	4	CCW		1848	
0231178006	4	CW		2845	
0231178017	4	CW		2842	
0231186023, 0231146077, 0231170307	4	CCW		1843	
0231308009	6	CW	79	1869	91869
JFU4 (Bosch) 22100B03G0 (Nissan)	4	CCW		2841	
VJ 3BR 2T	3	CW		1832	
VJ 3BR 4	3	CCW		1831	
VJU 4BL 33	4	CCW		2846	
<b>MANUFACTURED IN AUSTRALIA</b>					
9230062653 (Motorcraft), 9230062663 (Holden)	6	CW	79	1865	91865
9230063851 (Holden)	8	CW	79	1885	91885
9230063856 (Motorcraft)	8	CCW	79	1886	91886
<b>DELCO</b>					
1110224	6	CCW	56, 57	2161	
1111558	2	CW	51, 56, 57	1121	
1111702, 1110136	6	CW	55, 56, 57	1166	
1111709, 1112571	2	CCW	52, 56, 57	1123	
1111748	4	CW	55, 56, 57	1142	
1112457	3	CCW		1131	
1112576	2	CW	52, 56, 57	1122	
1112589, 1112577	4	CCW	56, 57	1143	



1847V

**FOOTNOTES**

- 1 Excluding California models
- 2 Factory electronic ignition
- 5 Canadian models only
- 10 Dual point distributor
- 20 Large cap distributor
- 27 Screw down cap
- 28 Clip down cap
- 33 Vacuum advance distributor
- 34 Non vacuum advance distributor
- 49 Distributor with tapered style rotor
- 50 Replacement rotor included
- 51 Fires every 180 degrees
- 52 Fires every 90 degrees
- 55 Also available in 6-volt negative ground, add N6 to part number
- 56 Also available in 6-volt positive ground, add P6 to part number
- 57 Also available in 12-volt positive ground, add P12 to part number
- 63 With four lobe point cam
- 64 With three lobe point cam
- 65 With eight lobe point cam
- 66 24-volt system
- 67 Mil-Spec Waterproof Ignition
- 79 Ignitor II applications can not be used with solid core ignition wires
- 88 Ignitor III kit available see page 4 for details

**ELECTRONIC IGNITION CONVERSIONS**

New applications appear in red

Description	Cyl.	Rotation	Footnotes	IGNITOR	Ignitor® II
<b>DUCELLIER</b>					
4155D, R251C34	4	CW		EP-141	
525294A	4	CCW		EP-142	
R275 E3A	4	CW		DU-141	
<b>MOTORCRAFT</b>					
C7NF 12127A	3	CCW		1231	
721F AHA 5JD, 71BB-AHB	4	CCW	79	1241	91241
76HF DA 5CC	4			1249	
<b>HITACHI</b>					
D4B 880-01 (Mexico)	4	CCW	13, 86	1742LS	
<b>HOLLEY</b>					
2562-1 69498	6	CW		HO-161A	
285096-C91	8	CW	83	HO-182	
<b>INTERNATIONAL HARVESTER</b>					
353898R1	4	CW		1442	
368051R1	6	CCW		1461	
<b>LUCAS</b>					
22D	6	CCW	57	LU-166A	
23D4	4	CCW		LU-148	
23D6	6	CCW		LU-162A	
25D4	4	CCW	57	LU-142A	
25D6	6	CCW	57	LU-162A	
35D8	8	CW	33, 84, 79	LU-181	9LU-181
35D8	8	CW	32, 79	LU-183	9LU-183
35D8	8	CCW	32	LU-185	
35DE8	8	CW		LU-281	
35M8 & 35DLM8	8	CW	2	LU-182A	
36DE12	12	CCW	2	LU-1122	
36DM12	12	CCW	2	LU-1121	
40068F	8	CCW	10, 33	LU-186	
43D4 / 45D4	4	CCW	45, 79	LU-143	9LU-143
43D4 / 45D4	4	CCW	46, 79	LU-144	9LU-144
43D6 / 45D6	6	CCW	45, 79	LU-163	9LU-163
46D6 / 45D6	6	CCW	46, 79	LU-164	9LU-164
45DE4, 47DE4	4	CCW	2, 79	LU-141	9LU-141
45DE6	6	CCW	2	LU-161	
45DM4 & 47DM4	4	CCW	2, 80	LU-147	
45DM6	6	CCW	2	LU-167	
D3A4 40748A	4	CCW		LU-145	
DM2 Early	4	CCW	13, 57, 70	LU-241LS	
DM2 Late	4	CCW	57, 71	LU-149	
<b>MITSUBISHI</b>					
T0T 00471	6	CCW	13, 86	1762LS	
T0T 00471, 22100 03510 (Nissan)	6	CCW	79	1762	91762
T1T 12371	4	CW		1948	
T2T 10496	4	CW		MA-141	
T3T 03571	4	CCW		1949	
T3T 04582	4	CW	79	1942	91942
T3T 05772	4	CW	79	1941	91941
T3T 07192	4	CW		1947	
T3T 07872	4	CW	79	1946	91946
T3T 16171, T4T 11071	4	CCW	79	1943	91943
T3T 61991	4	CW	79	1944	91944
T4T 66871	4	CW	79	1945	91945
<b>NIPPONDENSO</b>					
19100-60061 029100-1231	6	CW	79	1661	91661
19100-60062, 19100-60065 029100-2370	6	CW	79	1665A	91665A
19100-87219 229100-7580	3	CCW		1631	
19100-61130 029100-6851	6	CW	79	1662	91662
229100-3130 (Denso), MD100991 (Mitsubishi)	4	CW		1645	
33100-78410, 029100-7270	3	CW	79	1632	91632

## APPLICATION NOTES

Great effort has gone into insuring the accuracy of this guide. The following pages represent the most common makes and models of each application. To insure that you select the correct part number, use these general guidelines:

- Read all footnotes before ordering.
- Unless otherwise noted, part numbers listed represent 12-volt negative ground kits. Many kits are available in 6-volt negative ground, as well as 6 and 12-volt positive ground. Add an N6, P6 or P12 suffix to the part number when ordering.
- Applications are based on the vehicle's original equipment.
- An "LS" suffix indicates a Lobe Sensor version. Lobe Sensor technology senses the point cam, and does not use a magnet sleeve or magnet ring.
- Compatible coils can be found in the coil section of this catalog.
- If your application is not listed please contact us for information on possible custom kits.
- New applications appear in red.

Year	Cyl	Model	Footnotes	Dist No.	Dist Make	IGNITOR	Ignitor® II
<b>ANTIQUE BOATS</b>							
1949-62	4	Acadia - All models	55, 56, 57		Delco	1142	
1949-62	6	Acadia - All models	55, 56, 57		Delco	1167	
1974	4	Aeroceanic - All models	55, 79		Autolite	1548	91548
1948-54	4	Aerojet - Crosley CD	56	IGW-4181A, C	Autolite	1545	
1950-54	4	Aerojet - Crosley CD		IAD-4038	Autolite	2541	
1939-50	4	Arnolt - Sea-Mite	56	IGW-4118	Autolite	1545	
1946-47	4	Atlas - Her, IXB	56	IGW-4120, 92	Autolite	1545	
1938-40	6	Boat Engines Inc. - Hercules WXC3	55, 56, 57		Delco	1167	
1947-53	4	Brennan - Imp, Imp Jr.	56	IGW-6003-2A	Autolite	1545	
1938-55	4	Buchanan - All models	56	IGW-Series	Autolite	1545	
1936-55	6	Buchanan - All models	55, 56	IGW-Series	Autolite	1568	
1940-47	4	Buffalo Gas Motor - All models	55, 56, 57		Delco	1142	
1940-47	6	Buffalo Gas Motor - All models	55, 56, 57		Delco	1167	
All	V12	Scripps Engines - All models	60, 61	SM-1562 & SM-1563	Delco	DE-1121	
<b>CHEVROLET MARINE</b>							
1980-88	V6	All models	79	IBM-7021	Prestolite	1563	91563
1985-92	V6	All models	2	IDU-7602	Prestolite	2562	
1976-88	8	All models	58, 79	IBM-7011	Prestolite	1581	91581
1976-88	8	All models	58, 79	IBM-7013	Prestolite	1582	91582
<b>CHRIS-CRAFT</b>							
1975-80	4	FL181, FL153	79		Delco	1146A	91146A
1947-60	6	All models	55, 56, 79	IAY-4009	Autolite	1564	91564
1947-63	6	All models	55	IGC-4279A	Autolite	1567	
1967-71	6	All models	55, 79		Delco	1164	91164
1959-67	8	All models	10	1110630	Delco	1183	
1963-71	8	All models	55, 58, 79	IBM-4115, 4116	Prestolite	1581	91581
1981-85	8	All models	58, 79	IBM-7013	Prestolite	1582	91582
<b>CHRYSLER INBOARD</b>							
1967-71	6	155 (225 cu. in.)	79	2642513	Chrysler	1361A	91361A
1959-72	8	M80, M81, M318A, B, C, M413, D, M426X	55, 58, 79	IBM-4106	Prestolite	1581	91581
1965-66	8	M318X	55, 58, 79	IBM-4120	Prestolite	1581	91581
1983-88	8	273, 318, 340, 440 engine	58, 79	IBM-7016, 7017	Prestolite	1582	91582
<b>CRUSADER (THERMO-ELECTRON)</b>							
1985-92	V6	All models	2	IDU-7602	Prestolite	2562	
1961-69	8	283, 327, 409,	55, 58, 79	IBM-4110	Prestolite	1581	91581
1961-69	8	185, 220, 230 HP	56, 58, 79	YL431A, YD431A	Mallory	ML-181	9ML-181
1961-71	8	283, 327, 409, 427 engine.	79	1111161	Delco	1181	91181
1975-78	8	302 cid. engine.	58, 79	IBM-7007, A	Prestolite	1581	91581
1977-82	8	305, 350, 454 cid. engine.	58, 79	IBM-7011, C, D;	Prestolite	1581	91581
1983-87	8	305, 350, 454 cid. engine.	26, 58, 79		Mallory	ML-181	9ML-181
1987-88	8	305, 350, 454 cid. engine.	2, 79	IDU-7801	Prestolite	1589	91589



1589

### FOOTNOTES

- |  |  |   |
|--|--|---|
| <ul style="list-style-type: none"> <li>2 Factory electronic ignition</li> <li>10 Dual point distributor</li> <li>13 Lobe sensor module</li> <li>26 Excluding distributor number YL670AV</li> <li>32 Vacuum retard distributor</li> <li>33 Vacuum advance distributor</li> <li>45 With red fixed points</li> <li>46 With blue sliding points</li> <li>47 Vacuum retard &amp; advance distributor</li> </ul> | <ul style="list-style-type: none"> <li>55 Also available in 6-volt negative ground, add N6 to part number</li> <li>56 Also available in 6-volt positive ground, add P6 to part number</li> <li>57 Also available in 12-volt positive ground, add P12 to part number</li> <li>58 OMC, Stringer, Cobra and King Cobra applications with Electronic Shift Assist may require slight wiring modification.</li> <li>60 Dual distributor applications</li> </ul> | <ul style="list-style-type: none"> <li>61 Kit contains one module for each distributor</li> <li>70 Early DM2 distributor</li> <li>71 Late DM2 distributor</li> <li>79 Ignitor II applications can not be used with solid core ignition wires</li> <li>80 Excluding distributor number 41812A</li> <li>83 With plastic sliding point plate</li> <li>86 Requires modification to distributor</li> </ul> |
|--|--|---|

New applications appear in red

ELECTRONIC IGNITION CONVERSIONS

Year	Cyl	Model	Footnotes	Dist No.	Dist Make	IGNITOR	Ignitor® II
<b>DEARBORN MARINE</b>							
1960-69	8	262, 272, 292, 312	56, 58, 79	YL350A, YL387A	Mallory	ML-181	9ML-181
1961-69	8	221, 260, 289, 352, 390	26, 58, 79	YL362, 455, 519	Mallory	ML-181	9ML-181
1965-69	8	427	58, 79	YL494A-2, B-2	Mallory	ML-181	9ML-181
1966-69	8	260, 289, 302	79		Motorcraft	1281	91281
<b>FORD - (INTERCEPTOR)</b>							
1973-88	8	302, 351, 460 cid. engine.	28, 58, 79	IBM-7007, 08	Prestolite	1581	91581
1973-88	8	302, 351, 460 cid. engine.	27, 58, 79	IBM-7019, 20	Prestolite	1582	91582
<b>INDMAR PRODUCTS</b>							
1979	8	All models	79	IBM-7011	Prestolite	1581	91581
<b>MARINE POWER SYSTEMS</b>							
1978-83	8	305, 350, 454 cid. engine.	28, 58, 79	IBM-7011	Prestolite	1581	91581
1978-83	8	305, 350, 454 cid. engine.	27, 58, 79	IBM-7013	Prestolite	1582	91582
<b>MERCUISER (MERCURY MARINE)</b>							
All	4	110, 120, 140, 165, 170, 180, 190,	79		Delco	1146A	91146A
All	4	470, 470R, 485, 488R	79		Delco	1146A	91146A
All	6	140, 150, 160, 165, 200	79		Delco	1163A	91163A
All	6	Alpha 1 (120-140)	79		Delco	1163A	91163A
All	8	190, 225	79		Delco	1181	91181
All	8	233, 888	28, 79		Prestolite	1581	91581
All	8	233	27, 79		Prestolite	1582	91582
All	8	888	79	64025, 64026	Mercruiser	MC-181	9MC-181
All	8	198, 215, 225, 228, 250, 255, 260, 280	26, 79		Mallory	ML-181	9ML-181
All	8	330, 370, 400, 440, 460TRS	26, 79		Mallory	ML-181	9ML-181
All	8	888, 898, 5.7 Ski	26, 79		Mallory	ML-181	9ML-181
<b>OMC</b>							
1964-88	4	100, 110, 120, 140 HP	57, 79		Delco	1146A	91146A
1982-88	4	2.5 Ltr., 3.0 Ltr.	79	982351	Delco	1146A	91146A
1964-66	6	150 HP	79	1110309, 1110322	Delco	1163A	91163A
1967-72	6	155 HP	79	1110376	Delco	1164	91164
1972-76	6	165 HP	79	980156	Delco	1163A	91163A
All	V6	All models	2	IDU-7602	Prestolite	2562	
1966-88	8	All V8 engines with Mallory distributors	26, 58, 79		Mallory	ML-181	9ML-181
1974-88	8	All V8 engines with Prestolite distributors	28, 58, 79	980902, 981080, 982320	Prestolite	1581	91581
1982-88	8	All V8 engines with Prestolite distributors	27, 58, 79	IBM-7013C,D	Prestolite	1582	91582
<b>ONAN</b>							
1961-80	4	MDJC	56	IGW-4409A	Autolite	1545	
<b>PACEMAKER</b>							
1965-70	8	Pacer 185, 190, 210, 220, 250, 320 & Charger	19, 79	1111161	Delco	1181	91181
<b>PLEASURECRAFT</b>							
1975-78	8	Ford 302, 351, 460 cid. engine.	28, 58, 79	IBM-7007, IBM-7008	Prestolite	1581	91581
1976-82	8	305, 350, 454 cid. engine.	28, 58, 79	IBM-7011	Prestolite	1581	91581
1983-88	8	305, 350, 454 cid. engine.	27, 58, 79	IBM-7013	Prestolite	1582	91582
<b>TELEDYNE MARINE CO. (GRAY MARINE)</b>							
1950-69	6	F-6 Turbo	57, 79	YL411C, D	Mallory	ML-161	9ML-161
1950-69	8	138-178	56, 58, 79	YL429, C, D	Mallory	ML-181	9ML-181
1965-68	8	CF175, 195, CH175, 195	28, 58, 79	IBM-4119, A	Prestolite	1581	91581
All	8	401 cid. engine.	58, 79	YL455A, B; YL458B	Mallory	ML-181	9ML-181
<b>THERMO-ELECTRON</b>							
1977-82	8	305, 350, 454 cid. engine.	28, 58, 79	IBM-7011D	Prestolite	1581	91581
1981-82	8	305, 350, 454 cid. engine.	27, 58, 79	IBM-7013	Prestolite	1582	91582
<b>UNIVERSAL</b>							
1961-68	4	Atomic, Super, Unimite, Utility	56	IGW Series	Autolite	1545	
1968-70	4	Atomic Four	57, 79	1112446	Delco	1146A	91146A
1961-68	6	Super Sabre V6	79	1110322	Delco	1164	91164
1968-70	6	6 Cylinder	57, 79	YL370B	Mallory	ML-161	9ML-161
<b>VOLVO-PENTA</b>							
All	4	All models		231178017	Bosch	2842	
All	V6	All models	2	IDU-7602	Prestolite	2562	
1977-82	8	All models	28, 58, 79	IBM-7011A	Prestolite	1581	91581
1977-82	8	All models	27, 58, 79	IBM-7013A	Prestolite	1582	91582
1986-88	8	All models	2, 79	IDU-7801	Prestolite	1589	91589
<b>WAUKESHA</b>							
1959-73	4	IC, FC, FCS, FS (12 Volt)	56	IGW-4301-3	Autolite	1545	
1975-78	4	VGR-155	57, 79	1112470	Delco	1146A	91146A
<b>WISCONSIN</b>							
1948-57	4	VE4, VF4, VL4, VP4 (12 Volt)	56	IGW-Series	Autolite	1545	
1953-57	4	VG4, VR4	55, 56, 57, 79	IAD-6004-2F	Autolite	1541	91541
1957-85	4	V460D, VE-4, VF-4, VG4D, VP-4D, VH4, DM VR4D	55, 56, 57, 79	IAD-6004-2F, 2N	Autolite	1541	91541

## APPLICATION NOTES

Great effort has gone into insuring the accuracy of this guide. The following pages represent the most common makes and models of each application. To insure that you select the correct part number, use these general guidelines:

- Read all footnotes before ordering.
- Unless otherwise noted, part numbers listed represent 12-volt negative ground kits. Many kits are available in 6-volt negative ground, as well as 6 and 12-volt positive ground. Add an N6, P6 or P12 suffix to the part number when ordering.
- Applications are based on the vehicle's original equipment.
- An "LS" suffix indicates a Lobe Sensor version. Lobe Sensor technology senses the point cam, and does not use a magnet sleeve or magnet ring.
- Compatible coils can be found in the coil section of this catalog.
- If your application is not listed please contact us for information on possible custom kits.
- New applications appear in red.

Year	Cyl	Model	Footnotes	Dist No.	Dist Make	IGNITOR	Ignitor® II
<b>ALLIS CHALMERS</b>							
1957-58	4	4B-153, 4B-182	55, 56, 57, 79	IAD-6003-1A	Autolite	1541	91541
1965-68	4	H4 Crawler Tractor	22, 55, 57, 79	1112665	Delco	1145A	91145A
1969-72	4	FP-20, 30; FT20, 25; FTB30-24	22, 55, 57, 79	1112455	Delco	1145A	91145A
1969-72	4	FP-20, 30; FT20, 25; FTB30-24	24, 79	1112486	Delco	1146A	91146A
1969-72	4	F30, 40, 50; FP40, 50	24, 79	1112460	Delco	1146A	91146A
1971-74	4	G138, 160, 226	24, 79	1112688	Delco	1146A	91146A
1972	4	Model 600	22, 55, 57, 79	1112490	Delco	1145A	91145A
1973	4	AC-C20, 25, 30, 35, 40, 45, 50, 55;	22, 55, 57, 79	1112490	Delco	1145A	91145A
1973	4	AC-P20, 25, 30; FP-40, 55; Model 500	22, 55, 57, 79	1112490	Delco	1145A	91145A
1973	4	AC-C20, 25, 30, 35, 40, 45, 50, 55; AC-P20, 25, 30	24, 79	1112460, 86	Delco	1146A	91146A
1973	4	FP-40, 55; Model 500	24, 79	1112460, 86	Delco	1146A	91146A
1974	4	AC-C35, 40, 45, 50, 55; AC-P40, 50	24, 79	1112460	Delco	1146A	91146A
1975-82	4	Continental F163 engines	55, 57, 79	IBT-4701C	Prestolite	1542	91542
1976	4	Continental F163 engines	2, 21	IDJ-4008	Prestolite	2542	
1957-58	6	6B-230, 6B-273	56, 57, 79	IAD-6001-1B	Autolite	1561	91561
1967-69	6	TL545 Tractor Loader	56, 57, 79	1112668, 1111311	Delco	1163A	91163A
1969-73	6	F60, 70, 80, 100, 120, FP60, 70, 80	56, 57, 79	1112461	Delco	1163A	91163A
1969-74	6	G262	56, 57, 79	1112461	Delco	1163A	91163A
1973-74	6	All AC-C, AC-P Series	56, 57, 79	1112461	Delco	1163A	91163A
1975-82	6	All Continental F Series	55, 57, 79	IBT-6705, 01D	Prestolite	1562	91562
<b>AUTOCAR</b>							
1947-53	6	All models	56, 57, 79	IAD Series	Autolite	1561	91561
<b>BAKER</b>							
1961-66	4	Hercules IXLB engines	55, 56, 57, 79	IAD-6003B	Auto/Prestolite	1541	91541
1963-82	4	Continental F163 engines	55, 57, 79	IBT-4701	Prestolite	1542	91542
1960-62	6	Type Me-1A Towing Tractor with Chrysler engine	56, 57, 79	IAD-4039-1	Autolite	1561	91561
1972-81	6	Continental F226, F245 engines	55, 57, 79	IBT-6701D	Prestolite	1562	91562
<b>BAY CITY (CRANE)</b>							
All	6	15, 15A; 25, 30, 37, 45, T185, T50, T150, T180, T450	56, 57, 79	IAD, IGC Series	Autolite	1561	91561
<b>BROCKWAY</b>							
1952-66	6	All models	27, 34, 56, 57, 79		Delco	1163A	91163A
1950-71	6	All models	56, 57, 79	IAD, IGC Series	Auto/Prestolite	1561	91561
<b>BUDA</b>							
1951-56	4	FB	56	IGW-4118A	Autolite	1545	
1951-72	4	4B-153, 182	55, 56, 57, 79	IAD-6003-1A	Auto/Prestolite	1541	91541
1952-53	4	FT-30, 40, 50, 60, TG	55, 56, 57, 79	IAD-6003-1A	Autolite	1541	91541
1950-72	6	6B-190, 205, 221, 225, 230	56, 57, 79	IAD-6001-1B	Auto/Prestolite	1561	91561
1950-73	6	K-325, 369, 393, 428; L-468, 525; Lo-525	56, 57, 79	IGC-6001	Auto/Prestolite	1561	91561
1950-73	6	H-260, 298; HP-260, 298, 326, 351	56, 57, 79	IGC-6001	Autolite	1561	91561
1953-54	6	FT-60, 75; HA, HB, JG	56, 57, 79	IAD-6001-1B	Auto/Prestolite	1561	91561



1541

### FOOTNOTES

- |  |   |  |
|--|---|--|
| <p>2 Factory electronic ignition</p> <p>19 Mechanical advance at top of shaft</p> <p>21 See page 62 for complete replacement distributors</p> <p>22 Clockwise rotation</p> <p>24 Counter clockwise rotation</p> <p>26 Excluding distributor number YL670AV</p> <p>27 Screw down cap</p> <p>28 Clip down cap</p> <p>34 Non vacuum advance distributor</p> | <p>55 Also available in 6-volt negative ground, add N6 to part number</p> <p>56 Also available in 6-volt positive ground, add P6 to part number</p> <p>57 Also available in 12-volt positive ground, add P12 to part number</p> <p>58 OMC, Stringer, Cobra and King Cobra applications with Electronic Shift Assist may require slight wiring modification.</p> | <p>79 Ignitor II applications can not be used with solid core ignition wires</p> |
|--|---|--|

Year	Cyl	Model	Footnotes	Dist No.	Dist Make	IGNITOR	Ignitor II
<b>CASE</b>							
All	4	148 gas engine	55, 56, 57, 79	IAD-6003-2K	Autolite	1541	91541
All	4	Utility 435-LCK, (Own G188); 480CK	55, 56, 57, 79	IAD-6003-2J	Autolite	1541	91541
All	4	Lift Truck 580CK, (Own G159); Utility 500, 535, CLK	55, 56, 57, 79	IAD-6003-2F	Autolite	1541	91541
All	4	P-50 Hydra Place (Own G188)	55, 56, 57, 79	IAD-6003-2F	Autolite	1541	91541
All	4	SK1D (Gas, LPG)	55, 56, 57, 79	IAD-6003-1B	Autolite	1541	91541
All	4	319 Power Unit	55, 56, 57, 79	IAD-6003-2J	Autolite	1541	91541
All	4	Lift Trucks (Own VA 339)	55, 56, 57, 79	IAD-6003-2F	Autolite	1541	91541
All	4	W5AG (188 engine); 480CK, 580CK, (G-148, 159)	55, 57, 79	IBT-4403A	Prestolite	1542	91542
All	4	Utility 680CK, (Own A267)	79	IBT-4404, A	Prestolite	1542	91542
All	4	A-267; A-284G Power Unit, (Own A284)	79	IBT-4404, A	Prestolite	1542	91542
All	4	5400C Airport Tractor	55, 57, 79	IBT-4402A	Prestolite	1542	91542
All	4	W7, W9AG Loaders (A284 engine)	55, 57, 79	IBT-4402	Prestolite	1542	91542
All	4	1737S loader	2	IDD-4104	Prestolite	2542	
<b>CATERPILLAR</b>							
1976-80	4	Industrial engine	55, 57, 79	IBT-4701	Prestolite	1542	91542
1980-82	4	Lift Truck		IDJ-4005	Prestolite	2542	
1977	6	Industrial engine	21, 55, 57, 79	IBT-6702	Prestolite	1562	91562
1979	6	Lift Truck	21, 55, 57, 79	IDJ-4014	Prestolite	1562	91562
1979-80	8	Lift Truck (IHC-V345 engine)		IDN-4102B	Prestolite	1485A	
<b>CHEVROLET</b>							
1963-65	4	153 cid. engine with vacuum advance distributor	29, 79		Delco	1144A	91144A
1963-75	6	194, 230, 250, 292	8, 79		Delco	1162A	91162A
1956-76	8	All models	19, 79		Delco	1181	91181
1956-76	8	All models	13, 19		Delco	1181LS	
<b>CHICAGO PNEUMATIC TOOL CO.</b>							
1955-63	4	75PG-20	55, 56, 57, 79	IAD-6003B	Auto/Prestolite	1541	91541
1955-72	4	125RG-2	55, 56, 57, 79	IAD-4037	Auto/Prestolite	1541	91541
1958-71	4	125RG-1; 125RG-2 (Hercules G-2000 engine)	55, 56, 57, 79	IAD-4043	Auto/Prestolite	1541	91541
1959-73	4	85RG-2 (Continental F162 engine)	55, 56, 57, 79	IAD-6004-1C	Auto/Prestolite	1541	91541
1961-73	4	85RJ-1	21, 55, 57, 79	IBT-4705	Auto/Prestolite	1542	91542
1955-65	6	210RG-2	56, 57, 79	IAD-6001E	Auto/Prestolite	1561	91561
1961-73	6	85RJ-1	56, 57, 79	IAD-6001E	Auto/Prestolite	1561	91561
<b>CHRYSLER</b>							
All	6	5A, 6A, 7A, 8A, 13, 13A, 14A, 15A, 16A, 22A	56, 57, 79	IAD, IAO Series	Autolite	1561	91561
All	6	32, 33, 908A, 931	56, 57, 79	IAD, IAO Series	Autolite	1561	91561
All	6	5A, 6A	55, 57, 79	IAT Series	Autolite	1562	91562
All	6	H-170; H-225, 236, 251, 265, 313	55, 57, 79	IBR-4202	Auto/Prestolite	1562	91562
All	6	H-225	8, 79		Chrysler	1361A	91361A
All	8	H, HB, HT-318, HT-361, 413, 475, 476	8, 79		Chrysler	1381A	91381A
All	8	M273, ML318, ML340	79	IBM-7004B	Prestolite	1581	91581
<b>CLARK</b>							
1964-65	4	C-20, 20P, 20SU, 25, 25SU, 30, 40	21, 22, 55, 57, 79	1112637	Delco	1145A	91145A
1964-65	4	CF-20, 25; CY-20, 30	21, 22, 55, 57, 79	1112637	Delco	1145A	91145A
1966	4	C-20 - 50; CF-20, 30, 40, 50; Clarkette, Towtractor	21, 22, 55, 57, 79	1112673	Delco	1145A	91145A
1967-70	4	C-20, 20SU, 30B, 40B, 50B; CF-20, 30B, 40B, 50B	21, 22, 55, 57, 79	1112673	Delco	1145A	91145A
1967-70	4	CY-20, 25, 30B, 40B, 50B	21, 22, 55, 57, 79	1112673	Delco	1145A	91145A
1967-78	4	C-500-30, 35, 40, 45, 50, 55;	21, 79	1112685	Delco	1146A	91146A
1967-78	4	C-500H-40, 45, 55; Y-40, 45, 50, 55	21, 79	1112685	Delco	1146A	91146A
1969-71	4	Clarkette; IT-30, 40	21, 22, 55, 57, 79	1112673	Delco	1145A	91145A
1971	4	C-20, 25; CF-20, 25; CY-20; CFY-20	21, 22, 55, 57, 79	1112673	Delco	1145A	91145A
1972-78	4	C500-20, 20P, 25, 25P; C-500F-20P, 25P	2, 21, 55, 57, 79	IBT-4105	Prestolite	1542	91542
1972-78	4	C-500Y-20, 25, 30	2, 21, 55, 57, 79	IBT-4105	Prestolite	1542	91542
1972-78	4	C-500YF-20, 25, 30; IT-40B, Clarkat	2, 21, 55, 57, 79	IBT-4105	Prestolite	1542	91542
1972-78	4	C500-20, 20P, 25, 25P; C-500F-20P, 25P	21, 22, 55, 57, 79	1112673	Delco	1145A	91145A
1972-78	4	C-500Y-20, 25, 30	21, 22, 55, 57, 79	1112673	Delco	1145A	91145A
1972-78	4	C-500YF-20, 25, 30; IT-40B, Clarkat	21, 22, 55, 57, 79	1112673	Delco	1145A	91145A
1975-78	4	C500-30, 35, 40, 45, 50, 55; C-500H-40, 45, 50, 55	21, 79	1111700	Delco	1146A	91146A
1975-78	4	Y-40, 45, 50, 55	21, 79	1111700	Delco	1146A	91146A
1977-78	4	Clarkat; IT40B	21, 22, 55, 57, 79	1112673	Delco	1145A	91145A
1977-83	4	All models	21, 55, 57, 79	IBT-4706	Prestolite	1542	91542
1982	4	D176 (Waukesha engine)	2, 21	IDU-4403	Prestolite	2542	
1982	4	F163 TCM engine	2	IDU-4404	Prestolite	2542	
1982-84	4	Lift Truck	2	IDU-4003, 04	Prestolite	2542	
1956-66	6	All models	56, 57, 79	IAD-6001D	Auto/Prestolite	1561	91561
1964-65	6	C-60; CY-60; CFY-60	21, 56, 57, 79	1112628	Delco	1163A	91163A
1966	6	CT-20, 30, 40, 50; UT- 60, 70, 80, 100	21, 56, 57, 79	1112672	Delco	1163A	91163A
1966	6	HUT-60, 70, 80, 100; Y60, 100	21, 56, 57, 79	1112672	Delco	1163A	91163A
1966-70	6	C & CF 60, 70, 80; CH-60, 70, 80 CY-60, 70, 80	21, 56, 57, 79	1112672	Delco	1163A	91163A
1966-71	6	C-100, 120; CY-100, 120; Ranger 40, 60	21, 56, 57, 79	1112672	Delco	1163A	91163A
1967-69	6	IT-60	21, 56, 57, 79	1112672	Delco	1163A	91163A
1972-78	6	C-500H-60, 70, 80; C500-100, 200	21, 56, 57, 79	1112672	Delco	1163A	91163A
1972-78	6	C-500Y-100, 130, 150; Ranger 40, 60	21, 56, 57, 79	1112672	Delco	1163A	91163A

Year	Cyl	Model	Footnotes	Dist No.	Dist Make	IGNITOR	Ignitor II
<b>CLARK (CONTINUED)</b>							
1977-83	6	All models	21, 55, 57, 79	IBT-6703	Prestolite	1562	91562
1982	6	F227 TCM engine	55, 57, 79	IDU-4602	Prestolite	1562	91562
<b>CLIMAX</b>							
All	4	FM1, 3 engine	56	IGW-4120	Autolite	1545	
All	4	(Hercules NX engine)	56	IGW-4122	Autolite	1545	
All	4	(Waukesha ICK engine)	56	IGW-4118	Autolite	1545	
<b>CONTINENTAL</b>							
All	4	F4, G, H, J, N, Y engines	21, 55, 56, 57, 79	IAD Series	Autolite	1541	91541
All	4	F-163 engine	2	IDJ-4008	Prestolite	2542	
All	4	F4 engine	55, 57, 79	IBT-4501, 701	Auto/Prestolite	1542	91542
All	4	F4 and Y engines	21, 56	IGW Series	Autolite	1545	
All	4	F4 engine	21, 22, 55, 57, 79		Delco	1145A	91145A
All	6	B, E, M engines	21, 56, 57, 79	IAD-6002	Autolite	1561	91561
All	6	F6 engine	21, 56, 57, 79		Delco	1163A	91163A
All	6	F6, K, R, S, T, U engines	56, 57, 79	IAD Series	Autolite	1561	91561
All	6	F6, M engines	21, 55, 57, 79	IBT-6501, 701, 702	Auto/Prestolite	1562	91562
<b>CROSLLEY</b>							
All	4	Own CD engine	55, 56, 57, 79	IAD-4038	Autolite	1541	91541
All	4	Own CD engine	56	IGW-4181C	Autolite	1545	
<b>DATSUN / NISSAN</b>							
All	4	D-11, H-20 engines			Hitachi	1741	
All	4	H-20 engine	79		Mitsubishi	1943	91943
All	6	H-30, P-40 engine			Hitachi	1761	
<b>DODGE</b>							
1961-73	6	All models	8, 79		Chrysler	1361A	91361A
1973-81	6	All models	2, 15, 79		Chrysler	CH-161	9CH-161
1959-71	8	383, 413, 426, 440 cid. engine (Hemi Included)	10		Chrysler	1382	
1962-73	8	All models	8, 79		Chrysler	1381A	91381A
1969-73	8	All models	79		Holley	1481	91481
1973-81	8	All models	2, 15, 79		Chrysler	CH-181	9CH-181
1974-83	8	404, 446 cid.	2, 33, 79		Prestolite	1484A	91484A
<b>DUPLEX</b>							
All	6	Shovel Chassis, Wagon Crane, (B-6427, F6244)	21, 56, 57, 79	IAD-6002-1F	Autolite	1561	91561
<b>DYNA-TRUCK</b>							
1971	6	Dyna Mite 6-232, 258	79		Delco	1162A	91162A
<b>EARTH MASTER</b>							
All	4	C, CH, CN, CNH, D, DH	55, 56, 57, 79	IAD-6003-2A	Autolite	1541	91541
<b>EARTHMOVING EQUIPMENT</b>							
1967-69	8	All models	79	1112744	Delco	1181	91181
<b>EATON, YALE, TOWNE</b>							
1955-62	4	F-162 Continental engine	55, 56, 57, 79	IAD-6004-1D	Autolite	1541	91541
1963	4	All models	55, 56, 57, 79	IAD-4043	Autolite	1541	91541
1965-66	4	GLF, GLFP, GLFW, GLT	21, 22, 55, 57, 79	1112637	Delco	1145A	91145A
1968-75	4	JX4D Hercules engine	55, 56, 57, 79	IAD-4037	Autolite	1541	91541
1973-81	4	Mazda engine	2	IDJ-4010	Prestolite	2542	
1975-82	4	GC, GP 20-30 (Mazda engine)		9022313-00	Mazda	MA-141	
1976-77	4	F-163 Continental engine	2	IDJ-4008	Prestolite	2542	
1976-79	4	Ford engine	2	IDJ-4006	Prestolite	2542	
All	4	F-124 Continental engine	55, 56, 57, 79	IAD Series	Autolite	1541	91541
1955-60	6	All models	56, 57, 79	IAD-4039-1	Autolite	1561	91561
1969	6	Lift Truck	55, 57, 79	IBD-4009UT	Prestolite	1562	91562
1977-79	6	225 Chrysler engine	55, 57, 79	IDJ-4011	Prestolite	1562	91562
All	6	Chrysler engine	56, 57, 79	IAD-4039-1	Autolite	1561	91561
<b>ELGIN SWEEPER</b>							
1963-69	8	H Street King	79	1112744	Delco	1181	91181
1965-70	8	Pelican, White Wing, Fleet Wing	79	1112744	Delco	1181	91181



2542

### FOOTNOTES

<p>2 Factory electronic ignition</p> <p>8 Single point distributor</p> <p>10 Dual point distributor</p> <p>13 Lobe sensor module</p> <p>15 Excluding lean burn computer controlled engines</p> <p>19 Mechanical advance at top of shaft</p> <p>21 See page 62 for complete replacement distributors</p> <p>22 Clockwise rotation</p> <p>29 Excluding distributor number IAD-4036</p> <p>33 Vacuum advance distributor</p> <p>55 Also available in 6-volt negative ground, add N6 to part number</p>	<p>56 Also available in 6-volt positive ground, add P6 to part number</p> <p>57 Also available in 12-volt positive ground, add P12 to part number</p> <p>79 Ignitor II applications can not be used with solid core ignition wires</p>
---	--

Year	Cyl	Model	Footnotes	Dist No.	Dist Make	IGNITOR	Ignitor II
<b>ERICKSON</b>							
All	4	Loader HL3030, LC4D-G	21, 55, 56, 57, 79	IAD-6004-2N	Autolite	1541	91541
All	4	61, 200	21, 55, 56, 57, 79	IAD-6004-2F	Autolite	1541	91541
<b>FAGEOL PRODUCTS</b>							
All	4	Crosley engine	56	IGW-4181,401	Autolite	1545	
<b>FAIRMONT RAILWAY PRODUCTS</b>							
All	4	A5, A7A Gang Car	56	IGW-4118A	Autolite	1545	
All	4	Waukesha, ICK; (Hercules ZXB engine)	56	IGW-4301	Autolite	1545	
<b>FATE ROOT HEATH (SILVER KING)</b>							
All	4	440 (IXB-3 engine)	56	IGW-4120-1	Autolite	1545	
<b>FORD</b>							
All	4	172 & 192 engine	55, 56, 57	311185	FoMoCo	1244A	
1984	6	300 engine	79	E4JE-12127-BA	FoMoCo	1263	91263
1963-67	6	All models (excluding V-6 engine)	55, 79		Holley	1266	91266
1949-74	6	All models (excluding V-6 engine)	79		Motorcraft	1261	91261
1975-77	6	300 cid. engine	79	D5TE-12127VA	FoMoCo	1262	91262
1968-84	6	200 engine	79	D3JF-12127-BA	FoMoCo	1261	91261
1986	8	460 engine	2, 20, 79	E3TZ-12127-BAA	FoMoCo	FO-182	9FO-182
1974-76	8	All models	2, 17, 79		FoMoCo	FO-181	9FO-181
1958-78	8	All models (excluding '58 & '59 272 engine)	79		FoMoCo	1281	91281
1976-79	8	534 engine	2, 17, 79	D6HZ-12127-E	FoMoCo	FO-181	9FO-181
1977-83	8	All models	2, 20, 79		FoMoCo	FO-182	9FO-182
<b>FRIGIDKING</b>							
1965	4	Waukesha 1CK engine	55, 56, 57, 79	IAD-6004A	Autolite	1541	91541
<b>GALION IRON WORKS</b>							
All	4	3-5 Ton Roller	56	IGW-4159A	Autolite	1545	
All	6	5-8 Ton Roller	21, 56, 57, 79	IAD-6002-1F	Autolite	1561	91561
<b>GAMBLES FARMCREST</b>							
All	4	20, 30	55, 56, 57, 79	IAD-6002,03, 04	Autolite	1541	91541
All	6	40	56, 57, 79	IAD-6001-1B	Autolite	1561	91561
<b>GMC</b>							
1963-66	4	153 cid. engine	79		Delco	1144A	91144A
1960-64	6	305-C, 351, 401, 478 cid. V6 engine	79		Delco	1164	91164
1963-64	6	All models (excluding 305-C, 351, 401, 478 cid. V6)	79		Delco	1162A	91162A
1965-74	6	V6 engine	79		Delco	1162A	91162A
1958-76	8	All models	19, 79		Delco	1181	91181
1958-76	8	All models	13, 19		Delco	1181LS	
<b>HARRIS</b>							
All	6	PH-43, PH-53 (5A, 8A engine)	56, 57, 79	IAD-4039, 40	Autolite	1561	91561
All	6	SPH-88, F6WC, F8, F8WC	56, 57, 79	IAD Series	Autolite	1561	91561
<b>HERCULES ENGINE</b>							
All	4	G1400, 1600 (gas engine)	55, 56, 57, 79	IAD-6013	Autolite	1541	91541
All	4	G, GO, IX, IXB, JX, ZX, ZXA, ZXB, CU4-180, 00	55, 56, 57, 79	IAD Series	Autolite	1541	91541
All	4	IX, ZX Series	56	IGW Series	Autolite	1545	
All	4	G1600	55, 57, 79	IBT-4405	Prestolite	1542	91542
<b>HI-DYNAMIC</b>							
All	4	P-40 Platform Truck	55, 56, 57, 79	IAD-6004-2A	Autolite	1541	91541
All	4	HA (Waukesha FC engine)	56	IGW-4301	Autolite	1545	
1971-72	6	250C Crane	79	1112682	Delco	1163A	91163A
All	6	HF-HM (4WD Shovel), HMG, HR, HV	56, 57, 79	IAD-6001	Autolite	1561	91561
<b>HYSTER</b>							
1965-66	4	Lift Truck	21, 22, 55, 57, 79		Delco	1145A	91145A
1967-69	4	Challenger H40F, 50F, Lift Truck	21, 22, 55, 57, 79	1112443	Delco	1145A	91145A
1967-69	4	Spacesaver S-30B, 40B, 50B Lift Truck	22, 55, 57, 79	1112635	Delco	1145A	91145A
1967-69	4	Spacesaver S-40C, 50C Lift Truck	22, 55, 57, 79	1112677	Delco	1145A	91145A
1967-69	4	Spacesaver S-30B, 40B, 50B Lift Truck	79	1112627	Delco	1146A	91146A
1972-78	4	Challenger H-20, 25, 30, 60, 70	21, 22, 55, 57, 79		Delco	1145A	91145A
1972-78	4	Spacesaver S-20, 25, 30, 40, 50 Lift Truck	21, 22, 55, 57, 79		Delco	1145A	91145A
1978-79	4	Misc. Models	21, 55, 57, 79	IBT-4705	Prestolite	1542	91542
1979-83	4	Misc. Models	55, 57, 79	IBT-4707	Prestolite	1542	91542
All	4	450XL		326835	Mazda	MA-141	
1962	6	Challenger H250A Lift Truck	79	1110262	Delco	1164	91164
1963-66	6	Straddle Truck & Lift Truck	79	1110262	Delco	1164	91164
1965-66	6	Straddle Truck & Lift Truck	56, 57, 79	1110317	Delco	1163A	91163A
1967-78	6	Lift Truck	21, 56, 57, 79		Delco	1163A	91163A
1978-79	6	Misc. Models	21, 55, 57, 79	IBT-6702	Prestolite	1562	91562
1979-83	6	Misc. Models	55, 57, 79	IBT-6704	Prestolite	1562	91562



Year	Cyl	Model	Footnotes	Dist No.	Dist Make	IGNITOR	Ignitor II
<b>IHC TRUCK</b>							
1967-70	6	220, 241, 265, 282, 308 cid. engine	56, 57, 79		Delco	1162A	91162A
1969-71	6	406, 450, 501 cid. engine	8, 56, 57, 79		Delco	1162A	91162A
1971-74	6	258 cid. engine	56, 57, 79		Delco	1162A	91162A
1959-64	8	266, 304, 345 cid. engine	79		Delco	1181	91181
1964-70	8	478, 549 cid. engine	22, 79		Holley	1481	91481
1964-70	8	478, 549 cid. engine	24, 79		Holley	1482	91482
1964-83	8	266, 304, 345, 392 cid. engines	33		Prestolite	1483A	
1964-83	8	266, 304, 345, 392 cid. engines	34		Prestolite	1485A	
1968-71	8	266, 304 cid. engine	79		Holley	1481	91481
1971-78	8	All models	79		Holley	1481	91481
1974	8	400 cid. engine	19, 79		Delco	1181	91181
1974-83	8	304, 345, 392 cid. engine	34		Prestolite	1485A	
<b>J. A. FREEMAN</b>							
1959-73	4	25A, 25AW, 25ACWT, 26, 28; 100T, 100W	21, 55, 56, 57, 79	IAD-6004	Auto/Prestolite	1541	91541
1959-73	4	200T, 200W, 300T, 300W, 330W	21, 55, 56, 57, 79	IAD-6004	Auto/Prestolite	1541	91541
<b>JAEGER</b>							
All	4	60 Compressor	56	IGW-4156D	Autolite	1545	
All	4	75, 85 Compressors; 2HM Mixer	29, 79	IAD Series	Autolite	1542	91542
All	6	105, 125, 125A, B, 150, 160, 185, 250 "Air Plus"	29, 56, 57, 79	IAD Series	Autolite	1561	91561
All	6	315, 3HM, 4 1/2 HM Mixers	29, 56, 57, 79	IAD Series	Autolite	1561	91561
<b>JEEP INDUSTRIAL</b>							
All	6	225 engine	19, 43		Delco	1165	
All	6	232 engine	56, 57, 79	1110340, 366, 0444	Delco	1162A	91162A
<b>JOHN DEERE</b>							
1962-72	4	500, 500C 3020 Series Tractor	22, 55, 57, 79	1112474, 1112648	Delco	1145A	91145A
1962-70	6	600, 4020 Series Tractor	56, 57, 79	1112624	Delco	1163A	91163A
1971-72	6	420	56, 57, 79	1112466	Delco	1163A	91163A
<b>KAISER JEEP</b>							
All	4	FJ, F4-134, L4-134	55, 56, 57, 79	IAD-4008A,4041	Autolite	1541	91541
<b>KOMATSU</b>							
All	4	Hercules 1600 engine	2		Prestolite	2542	
1990 later	4	Nissan engines			Hitachi	1741	
1990 earlier	4	Nissan engines	79		Mitsubishi	1943	91943
All	6	P-40 engine			Hitachi	1761	
<b>LE ROI</b>							
All	4	D-71, K-3, W, X, V, Y	56	IGW Series	Autolite	1545	
All	4	D-133, D-140, V, W, W-3, X, Y	56	IGW-4121A	Autolite	1545	
<b>LINCOLN WELDERS</b>							
1978-82	4	All models	21, 55, 57, 79	IBT-4705	Auto/Prestolite	1542	91542
1962-66	6	Hercules JXD, QXLD-5 engine	56, 57, 79	IGC-6001-2D	Auto/Prestolite	1561	91561
<b>LYCOMING SPENCER ENGINES</b>							
All	4	CV-4-180	55, 56, 57, 79	IAD-6004-1G	Autolite	1541	91541
<b>MASSEY FERGUSON</b>							
1956-59	4	MHF-3, 4	55, 56, 57, 79	IAD-6004-2H	Autolite	1541	91541
1963-64	4	MF-202, 204, 356 Tractor	22, 55, 57, 79	1112643	Delco	1145A	91145A
1966-68	4	MF-302, 304, 356, 2135, 2200, 2500, 3165	22, 55, 57, 79	1112643	Delco	1145A	91145A
1969	4	MF-3165 Tractor	22, 55, 57, 79	1112458	Delco	1145A	91145A
1971-78	4	MF-30 Tractor	22, 55, 57, 79	1112458	Delco	1145A	91145A
1974-78	4	MF-4000, MF-4500, MF6000	22, 55, 57, 79	1112693	Delco	1145A	91145A
All	4	MF302, 304, 356 (Continental GF-193 engine)	22, 55, 57, 79	1112644	Delco	1145A	91145A
All	4	MF2135, MF2200, MF2500 (Continental engine)	22, 55, 57, 79		Delco	1145A	91145A
All	6	MF1100, MF1105 (Waukesha F320G, LPG)	56, 57, 79		Delco	1163A	91163A



1545



1145A

### FOOTNOTES

- 2 Factory electronic ignition
- 8 Single point distributor
- 13 Lobe sensor module
- 17 Small cap distributor
- 19 Mechanical advance at top of shaft
- 20 Large cap distributor
- 21 See page 62 for complete replacement distributors
- 22 Clockwise rotation
- 24 Counter clockwise rotation
- 29 Excluding distributor number IAD-4036
- 33 Vacuum advance distributor
- 34 Non vacuum advance distributor
- 43 Odd fire engine
- 55 Also available in 6-volt negative ground, add N6 to part number
- 56 Also available in 6-volt positive ground, add P6 to part number
- 57 Also available in 12-volt positive ground, add P12 to part number
- 79 Ignitor II applications can not be used with solid core ignition wires

Year	Cyl	Model	Footnotes	Dist No.	Dist Make	IGNITOR	Ignitor II
<b>MICHIGAN</b>							
All	6	C16, C24, T6K, T64, T66, TLDT-20, TMDT-16, -20	56, 57, 79		Autolite	1561	91561
<b>MINNEAPOLIS-MOLINE</b>							
1950-66	4	M (Hercules IBX engine)	55, 56, 57, 79	IAD-6003B	Auto/Prestolite	1541	91541
1950-66	4	B (Continental Y-112 engine)	21, 56	IGW-4139	Auto/Prestolite	1545	
1962-78	4	MA-30, MA-40, MA-50 Lift Truck	55, 57, 79	IBT-4702	Prestolite	1542	91542
1965-66	4	HD-220-4A Power Unit	22, 55, 57, 79	1112671	Delco	1145A	91145A
1965-71	4	HD-336A-4A Power Unit	57, 79	1112660, 661	Delco	1146A	91146A
1966-68	4	MY-40, MY-60 Lift Truck	22, 55, 57, 79	1112642, 671	Delco	1145A	91145A
1968-72	4	MA-20, MA-25, WC-20, WC-25, WC-305 Lift Truck	56	IGW-4303	Autolite	1545	
1969-71	4	HD-220-4A Power Unit	22, 55, 57, 79	1112642	Delco	1145A	91145A
1950-66	6	D, L Chrysler 30 engine	56, 57, 79	IAD-4039-1	Auto/Prestolite	1561	91561
1963-71	6	HD-425-6A, 504A-6A, 605A-6A, 800-6A Power Unit	56, 57, 79	1112638	Delco	1163A	91163A
1974-78	6	G-1400, 1600 (Hercules gas engine)	56, 57, 79	IAD-6013	Prestolite	1561	91561
<b>MITSUBISHI</b>							
All	4	4G33 engine	79	MD-009102	Mitsubishi	1941	91941
All	4	4G52 engine	79	MD-025752	Mitsubishi	1942	91942
<b>MOBILIFT</b>							
All	4	M, MSA (Hercules IBX engine)	21, 55, 56, 57, 79	IAD-6003, 4	Autolite	1541	91541
All	4	MA-30, MA-40, MA-50	55, 57, 79	IBT-4702	Prestolite	1542	91542
All	4	B (Continental Y-112 engine)	21, 56	IGW-4139	Autolite	1545	
All	6	D, L (Chrysler 30 engine)	56, 57, 79	IAD-4039-1	Autolite	1561	91561
<b>NEW IDEA</b>							
1965-72	6	701, 702 Power Unit	56, 57, 79		Delco	1163A	91163A
<b>NEWARK OHIO CO.</b>							
All	6	701 Power Unit (Continental F245 engine)	21, 56, 57, 79	1111310	Delco	1163A	91163A
<b>ONAN</b>							
All	4	(55-50 Willys engine)	55, 56, 57, 79	IAD-4008	Autolite	1541	91541
All	4	(56-55 Willys engine)	56	IGW-4115	Autolite	1545	
All	4	5GO, 6GO, HC, HQ	56	IGW-4156C	Autolite	1545	
All	4	All models	56	IGW-4409A	Autolite	1545	
All	6	15K, 25HN (5A, 6A engine)	56, 57, 79	IAD-4039-1	Autolite	1561	91561
<b>PETTIBONE MERCURY</b>							
1978-80	4	(F-163 Continental engine)	2, 21	IDJ-4008	Prestolite	2542	
1979-82	6	All models	21, 55, 57, 79	IDJ-4013	Prestolite	1562	91562
<b>READY POWER</b>							
All	4	F2, F4 (Ford engine)	55, 56, 57, 79	IAD-4008	Autolite	1541	91541
All	4	Z, Z-2 (Hercules ZXB engine)	56	IGW-4120B	Autolite	1545	
All	6	1959, F, L2, L3, V	56, 57, 79	IAD-6002-1G	Autolite	1561	91561
<b>REO</b>							
1954-66	8	OV-195, 207, 235, 390, 440 engines	79		Delco	1181	91181
1966-71	8	130B, 145B, engine	79	D-4141A	Holley	1481	91481
1966-77	8	OV-235, B engine	79	D-4292A, -1A, AAS	Holley	1481	91481
<b>ROSS CARRIER</b>							
All	4	Series 5 Lift Truck	55, 56, 57, 79	IAD-6004-2C	Autolite	1541	91541
All	6	Series 12T, Y200 Lift Truck, Series 80, 90, 100 Carrier	56, 57, 79	IAD Series	Autolite	1561	91561
<b>SEAMAN AND WALL</b>							
All	6	GS7C	56, 57, 79	IAD-6002-1A	Autolite	1561	91561
<b>TCM</b>							
All	4	FG, FCG 10-25 Series Lift Truck (Nissan H-20 engine)			Hitachi	1741	
All	6	FG, FCG 30, 35 Series Lift Truck (Nissan H-30 PPU)			Hitachi	1761	
<b>TEREX DIVISION (G.M.C.) (WITH CONTINENTAL ENGINE)</b>							
1972	4	T-30, 40, 50, 60, V-30, 40, 41, 50, 51, 60, Lift Truck	22, 55, 57, 79	1112677	Delco	1145A	91145A
1972	6	540, 600, 670, 760-P, 860-P, 960-PLT	22, 56, 57, 79	1112444	Delco	1163A	91163A
1972	6	V-30, 40, 41, 50, 51, 60	22, 56, 57, 79	1112444	Delco	1163A	91163A
<b>THERMO-KING</b>							
All	4	Thermo King MQ-21 Refrig. Unit	55, 56, 57, 79	IAD-4038	Autolite	1541	91541
All	4	Waukesha 1CK engine	55, 56, 57, 79	IAD-6004A	Autolite	1541	91541
<b>TOWMOTOR</b>							
1950-51	4	LT-40, 44, 48, 50, 60	56	IGW-4044A	Autolite	1545	
1950-56	4	LT-35, 350	56	IGW-4044A, 4191A	Autolite	1545	
1955-62	4	Continental Y-91 engine	55, 56, 57, 79	IAD-6004-1D	Autolite	1541	91541
1957-65	4	350 Lift Truck Continental N-62	56	IGW-4191A	Autolite	1545	
1959-70	4	331 Lift Truck	56	IGW-4403A	Auto/Prestolite	1545	
1960-70	4	442, 462, 502P, 601P	55, 57, 79	IBT-4701A	Prestolite	1542	91542
1962-70	4	502, 601	55, 57, 79	IBT-4701C	Prestolite	1542	91542
1965-67	4	350 Lift Truck	56	IGW-4501	Autolite	1545	
1966-73	4	Lift Truck Waukesha 1CK engine	56	IGW-4502	Auto/Prestolite	1545	
1970-79	4	Lift Truck	55, 57, 79	IBT-4701C	Prestolite	1542	91542
1971-80	4	Continental F, Y engine	55, 57, 79	IBT-4701C	Prestolite	1542	91542
1972	4	Lift Truck; T-30, 40, 50, 60; V30, 40, 41, 50, 51 60	22, 55, 57, 79	1112677	Delco	1145A	91145A

Year	Cyl	Model	Footnotes	Dist No.	Dist Make	IGNITOR	Ignitor® II
<b>TOWMOTOR</b>							
1975-78	4	V60C Lift Trucks Perkins G4-236 engine	2	IDJ-4005	Prestolite	2542	
1976-80	4	V60-80 Lift Trucks Perkins G4-236 engine	2	IDJ-4005A	Prestolite	2542	
1978-79	4	All Y112, F163, F185 Continental engine	2, 21	IDJ-4012	Prestolite	2542	
1962	6	Lift Truck; 850, 950	56, 57, 79	1112622, 630	Delco	1163A	91163A
1972	6	Lift Truck; Continental F227 engine	56, 57, 79	1112444	Delco	1163A	91163A
1972-79	6	Lift Truck Continental F226, F245 engine	21, 55, 57, 79	IBT-6702	Prestolite	1562	91562
1977	6	Continental F227, 245 engine	55, 57, 79	IDJ-4013	Prestolite	1562	91562
1979	8	Large Lift Truck V345 engine	2	IDN-4102B	Prestolite	1485A	
<b>TOYOTA INDUSTRIAL</b>							
All	4	FG-25, FGC-15, FGC-25, 2FGC-20,	79		Toyota	1641	91641
All	4	3-FG-10, 15; 3-FGC-20, 25; 4-FGC-20, 25	79		Toyota	1641	91641
All	4	02-FG-25, 02-FGC-10, 02-FGC-15, 02-FGC-20,	79		Toyota	1641	91641
All	4	02-FGC-25, 40-FG-20, 42-FG-20	79		Toyota	1641	91641
All	4	FGC-10 (5R engine)	79		Toyota	1641	91641
All	6	2FG-50, 60, 3FG-32, 35, 40, 50, 60	79		Toyota	1661	91661
All	6	FG-32, 35, 40 (F engine), 2FG-32, 35, 40 (2F engine)	79		Toyota	1665A	91665A
<b>UNIVERSAL</b>							
All	4	AF	56	IGW-4116A	Autolite	1545	
<b>US MOTORS</b>							
All	4	All models	55, 56, 57, 79	IAD-4037, 6004	Autolite	1541	91541
All	4	All models	56	IGW-4022, 120	Autolite	1545	
All	6	All models	56, 57, 79	IAD-6002-1A	Autolite	1561	91561
<b>VOLKSWAGEN INDUSTRIAL ENGINE</b>							
1969-72	4	Type 122/2, Type 126/A		231117007	Bosch	1847V	
1971-75	4	Type 127 (1m 127 engine)		231117007	Bosch	1847V	
1973-75	4	Type 122/2, Type 126/A ((1m 122 engine)		231178003, 009	Bosch	1847V	
<b>WAUKESHA</b>							
1950-73	4	IC series	56	IGW-4118A, 4301	Autolite	1545	
1959-67	4	FC, FCS, FS14	56	IGW-4301, 4303	Auto/Prestolite	1545	
1972-73	4	FC-4	22, 55, 57, 79	1112455	Delco	1145A	91145A
1972-74	4	18GKB	79	1112463, 470	Delco	1146A	91146A
1975-78	4	VRG-155 engine	79	1112470	Delco	1146A	91146A
All	4	H-1077G	22, 55, 57, 79		Delco	1145A	91145A
All	4	FC series	22, 55, 57, 79	1112455	Delco	1145A	91145A
All	4	180 DCK, GKB	79	1112463, 470	Delco	1146A	91146A
1963-66	6	190	56, 57, 79	1112682	Delco	1163A	91163A
1967-70	6	265G, 283	56, 57, 79	1112682	Delco	1163A	91163A
1968-70	6	320G, LPG	56, 57, 79	1112687, 696	Delco	1163A	91163A
1968-73	6	F-554G Standard	56, 57, 79	1112465	Delco	1163A	91163A
1968-82	6	F-817G, F1197G Standard	56, 57, 79	1112465	Delco	1163A	91163A
All	6	135GZ	56, 57, 79	1112462	Delco	1163A	91163A
All	6	195GK, F320G	56, 57, 79	1112687, 96	Delco	1163A	91163A
<b>WHITE</b>							
1969-72	4	MY-40, 50, 60, 70	22, 55, 57, 79	1112642	Delco	1145A	91145A
1972	4	HD-425A-6A, 336A-4 1, 504A-6A, 605B-6A, 800-6A	79	112660, 661	Delco	1146A	91146A
1975-81	4	MA20, 25, 30, Lift Truck	22, 55, 57, 79	1112487	Delco	1145A	91145A
1976-82	4	Misc. Models	55, 57, 79	IBT-4702, 4405	Prestolite	1542	91542
1977-83	4	G-1600	55, 56, 57, 79	IAD-6013	Prestolite	1541	91541
1969-74	6	MA20 thru MA100, WC-20, 30, 40, 50	56, 57, 79	1112444	Delco	1163A	91163A
1975-81	6	MA60H, 70, 80, 90, 100, 120 Lift Truck	56, 57, 79	1112444	Delco	1163A	91163A
1966-69	8	470 cid. engine	79	D-4108A	Holley	1481	91481



1941



1641

### FOOTNOTES

- 2 Factory electronic ignition
- 21 See page 62 for complete replacement distributors
- 22 Clockwise rotation
- 55 Also available in 6-volt negative ground, add N6 to part number
- 56 Also available in 6-volt positive ground, add P6 to part number
- 57 Also available in 12-volt positive ground, add P12 to part number
- 79 Ignitor II applications can not be used with solid core ignition wires



## APPLICATION NOTES

Great effort has gone into insuring the accuracy of this guide. The following pages represent the most common makes and models of each application. To insure that you select the correct part number, use these general guidelines:

- Read all footnotes before ordering.
- Unless otherwise noted, part numbers listed represent 12-volt negative ground kits. Many kits are available in 6-volt negative ground, as well as 6 and 12-volt positive ground. Add an N6, P6 or P12 suffix to the part number when ordering.
- Applications are based on the vehicle's original equipment.
- An "LS" suffix indicates a Lobe Sensor version. Lobe Sensor technology senses the point cam, and does not use a magnet sleeve or magnet ring.
- Compatible coils can be found in the coil section of this catalog.
- If your application is not listed please contact us for information on possible custom kits.
- New applications appear in red.

Year	Cyl	Model	Footnotes	Dist No.	Dist Make	IGNITOR	Ignitor II
<b>ALLIS CHALMERS</b>							
All	4	Baler models 300, 302, 303	21, 55, 56, 57, 79	IAD-6004	Autolite	1541	91541
All	4	Sprayer '2300	21, 55, 56, 57, 79	IAD-6004	Autolite	1541	91541
All	4	Tractor models 170, 175	79	1112688	Delco	1146A	91146A
All	6	Models E, E-111, K	56, 57, 79	1112479, 640	Delco	1163A	91163A
All	6	F, G262, B, GB230, G250, G292 engine	56, 57, 79	1112461, 479, 640	Delco	1163A	91163A
All	6	G, 2800 (gas engine)	56, 57, 79	1112472	Delco	1163A	91163A
All	6	K, 6-250, 6-232 engine	56, 57, 79	1112479	Delco	1163A	91163A
All	6	180, 190XT, 200, 226	56, 57, 79	1112668	Delco	1163A	91163A
All	6	190 (G-2500 gas, LPG engine )	56, 57, 79	1111311, 2653, 667	Delco	1163A	91163A
<b>BESLER</b>							
All	4	450 Wisconsin VG4	21, 55, 56, 57, 79	IAD-6004	Autolite	1541	91541
<b>BOLENS</b>							
All	4	Wisconsin VG4D	21, 55, 56, 57, 79	IAD-6004	Autolite	1541	91541
<b>BRADY</b>							
All	4	BPO60-DKB, T60DKM (Wisconsin VG4D)	21, 55, 56, 57, 79	IAD-6004	Autolite	1541	91541
<b>CARDOX</b>							
All	4	Jeep F-4 engine	55, 56, 57, 79	IAD-4041	Autolite	1541	91541
All	4	Wisconsin engine VG4D	21, 55, 56, 57, 79	IAD-6004	Autolite	1541	91541
<b>CASE</b>							
All	4	700, 730, 734, 740, 770, 800, 830 Tractors	24, 55, 56, 57, 82	X30091E	Wico	WO-141	
All	4	840, 870, 900B, 930, 940, 970 Tractors	24, 55, 56, 57, 82	X30091E	Wico	WO-141	
All	4	W5 G188 engine	55, 56, 57, 79	IAD-6003	Autolite	1541	91541
All	4	177 Wisconsin VG4D	21, 55, 56, 57, 79	IAD-6004	Autolite	1541	91541
All	4	330 (Wisconsin VG4D, VH4D)	55, 56, 57, 79		Autolite	1541	91541
All	4	65 Wisconsin VF4	55, 56, 57, 79		Autolite	1541	91541
All	4	150, 302, 400, 600, 660, (Hercules G-188B, A201)	79		Autolite	1541	91541
All	4	200, 300 (Continental F140 engine)	55, 56, 57, 79	IAD-6004	Autolite	1541	91541
All	4	300, 400, 500 (Continental F162, FA162 engine)	55, 56, 57, 79	IAD-6004	Autolite	1541	91541
All	4	310, 320, G148	55, 56, 57, 79	IAD-6003	Autolite	1541	91541
All	4	440, 640 G148, G188 engine	55, 56, 57, 79	IAD-6003	Autolite	1541	91541
All	4	GT25, 30, 34 (Continental F124, F140, F162 engine)	55, 56, 57, 79	IAD-6004	Autolite	1541	91541
All	4	W5 G188 engine	55, 56, 57, 79	IAD-6003	Autolite	1541	91541
All	4	S, VA Series	55, 56, 57, 79	IAD-6003	Autolite	1541	91541
All	4	200, B, 210, B, 211B G126, 148, 188 engine	55, 56, 57, 79		Autolite	1541	91541
All	4	200B, 350, 351, 400B, 500B, 600B, (G126, G164)	55, 56, 57, 79	IAD-6003	Autolite	1541	91541
All	4	300, 310, 320, (G148)	55, 56, 57, 79	IAD-6003	Autolite	1541	91541
All	4	350, 351, 500B, 600B, (G164)	79	IAD-6003	Autolite	1541	91541
All	4	400, 440, 441, 80CK (G148, B)	79	IAD-6003	Autolite	1541	91541
All	4	540, C541, C (159); 640, 641, C	55, 56, 57, 79	IAD-6003	Autolite	1541	91541
All	4	400B, 420, 430, 435LCK, 440, 441, 450, 500	55, 56, 57, 79		Autolite	1541	91541



1541



1163A

### FOOTNOTES

- 21 See page 62 for complete replacement distributors
- 22 Clockwise rotation
- 24 Counter clockwise rotation
- 55 Also available in 6-volt negative ground, add N6 to part number
- 56 Also available in 6-volt positive ground, add P6 to part number
- 57 Also available in 12-volt positive ground, add P12 to part number
- 79 Ignitor II applications can not be used with solid core ignition wires
- 82 Will not fit magneto type distributors

New applications appear in red

ELECTRONIC IGNITION CONVERSIONS

Year	Cyl	Model	Footnotes	Dist No.	Dist Make	IGNITOR	Ignitor II
<b>CASE (CONTINUED)</b>							
All	4	400 (F162 engine)	55, 56, 57, 79		Autolite	1541	91541
All	4	530, 30LCK, 540, 41, C, C570, 80, CK, CK-B	55, 56, 57, 79	IAD-6003	Autolite	1541	91541
All	4	600B, G30, 640, C, 641, C	55, 56, 57, 79		Autolite	1541	91541
All	4	700B, 800, 800B, 900B	55, 56, 57, 79		Autolite	1541	91541
All	4	650, 655, 675 (Wisconsin VH4D, VG4D engine)	55, 56, 57, 79		Autolite	1541	91541
All	4	1150, 1155, (G159), 1255 (G188)	21, 55, 56, 57, 79	IAD-6003-2F	Autolite	1541	91541
All	4	V461D; (Own G159, G188, B)	55, 56, 57, 79		Autolite	1541	91541
All	4	800 (Hercules GO-298 A-251G, A-284G-F engine)	55, 57, 79		Prestolite	1542	91542
All	4	1000, 1010 (Hercules GO-289 A-215G, A-284G-F)	55, 57, 79		Prestolite	1542	91542
All	4	W7, W9AG 284 engine	55, 57, 79	IBT-4402	Prestolite	1542	91542
All	4	W5AG 188 engine	55, 57, 79	IBT-4403A	Prestolite	1542	91542
All	4	470 (G148, B, G159 engine)	55, 57, 79	IAD-6003	Prestolite	1542	91542
All	4	680CK A267	55, 57, 79		Prestolite	1542	91542
All	4	251, A301GB; 830, 840, 870	55, 57, 79		Prestolite	1542	91542
All	4	NCM, NT Wisconsin VE4	56	IGW-4159A	Autolite	1545	
All	4	A Wisconsin VF4	56	IGW-4159A	Autolite	1545	
All	4	V, VC, VI, VO Continental F124 engine	56		Autolite	1545	
All	4	840 (Wisconsin VE4; Own A -125 engine)	56	IGW-4159A	Autolite	1545	
All	6	600, 600G, 800G (Continental F209; H227 engine)	56, 57, 79	IAD-6002-1G	Autolite	1561	91561
All	6	900 (gas and LPG engine)	56, 57, 79	IAD-6010-1	Autolite	1561	91561
All	6	970 (377BG, A401 engine)	55, 57, 79		Prestolite	1562	91562
<b>CENTAUR</b>							
All	4	Hi-Way Mower, KV Tractor	56	IGW-4121A	Autolite	1545	
<b>COCKSHUTT</b>							
All	4	7, 18, 422 (Continental F-124, 140 engine)	55, 56, 57, 79	IAD-6004	Autolite	1541	91541
All	4	101, 102, 103, 620, 720 (Wisconsin engine)	21, 55, 56, 57, 79	IAD-6004	Autolite	1541	91541
All	4	10, 12, 14, 16 Ft., 502 Windrower	21, 55, 56, 57, 79	IAD-6004	Autolite	1541	91541
All	4	20, 30, (Continental F-124, 140 engine) GO-198	56, 57, 79	IAD-6004	Autolite	1541	91541
All	6	SP-109, 110, 112, 115, 132, 137, 215, 420	56, 57, 79	IAD-4040-1	Autolite	1561	91561
All	6	427, 28, 29; 430, 431, 525, 535, 542, 545	56, 57, 79	IAD-4040-1	Autolite	1561	91561
All	6	40 (Chrysler T-120, 8A engine)	56, 57, 79	IAD-4203-1	Autolite	1561	91561
<b>CUSTOM</b>							
All	6	B, C, E, ER, EW, HR, HW	79	IAD Series	Autolite	1561	91561
<b>FORD</b>							
All	3	Series 2000, 2100, 2110, 3100, 3400			FoMoCo	1231	
All	3	Series 4000, 4100, 4140, 4200			FoMoCo	1231	
1939-50	4	2N, 9N	23, 56		FoMoCo	1247	
All	4	8N	23, 56		FoMoCo	1247	
All	4	8N, series 500 thru 900	25, 55, 56, 57		FoMoCo	1244A	
All	4	2N, 8N, 9N	23, 31, 56		FoMoCo	1247XT	
All	4	16-46, 47, 48, 49; 16-98, 99, 100, 101	55, 56, 57, 79		Autolite	1541	91541
All	4	17-14, 15, 16, 17 Wisconsin VF4D	55, 56, 57, 79		Autolite	1541	91541
All	4	19-14, 15, 16, 17	55, 56, 57, 79		Autolite	1541	91541
1965-76	4	5000, 5100, 5000 Super, 5200, 6000, 6600			FoMoCo	1249	
All	6	17-1, 17-34, 17-35	79		FoMoCo	1261	91261
All	6	630, 640 Ford 300 engine	79		FoMoCo	1261	91261
<b>FOX RIVER</b>							
1958-59	6	Forage Harvester	56, 57, 79	IAD-6002-1G	Autolite	1561	91561
<b>FRIEND</b>							
All	4	ATB, ATB40, CU32, CU32RC, GTA, GTAT50, MA36	21, 55, 56, 57, 79		Autolite	1541	91541
All	4	MA36, MA36RC, MAL36RC; 322, 362,	21, 55, 56, 57, 79	IAD-6004	Autolite	1541	91541
<b>GEHL (FORAGE HARVESTER)</b>							
All	4	HL3030 Hydra Cat.	21, 55, 56, 57, 79	IAD-6004-2N	Autolite	1541	91541
All	4	Wisconsin VG4D engine	21, 55, 56, 57, 79	IAD-6004-2F	Autolite	1541	91541
All	6	Continental FA-244, M-363 engine	56, 57, 79	IAD-6002-	Autolite	1561	91561
<b>HAGIE</b>							
All	4	320, 340, 430, 432, 435, W; 437 Crane	21, 55, 56, 57, 79	IAD-6004-2F	Autolite	1541	91541
All	4	H300, FSP, P, H306, FSP, P	21, 55, 56, 57, 79	IAD-6004	Autolite	1541	91541
All	4	Hi. Boy, FS, Sprayer & Power Unit, VH4D engine	21, 55, 56, 57, 79	IAD-6004	Autolite	1541	91541
<b>HARDIE MFG. CO.</b>							
All	4	Wisconsin VG4D	21, 55, 56, 57, 79	IAD-6004	Autolite	1541	91541
All	4	DF24B, DF480C, DF485C, F4 engine	21, 55, 56, 57, 79	IAD-4012, 41	Autolite	1541	91541
All	4	150-160 Continental F-226 engine	55, 56, 57, 79		Autolite	1541	91541
All	4	VP4D (Wiscon engine)	56	IGW-4159A	Autolite	1545	
<b>HARRINGTON</b>							
All	4	Combine	21, 55, 56, 57, 79	IAD-6004-2F	Autolite	1541	91541
<b>HESSTON</b>							
All	4	110, 180, 260, 280, 300, 310 (Wiscon engine)	21, 55, 56, 57, 79	IAD-6004	Autolite	1541	91541
All	4	HS220, HS240, HS260, HS500 (Wiscon engine)	21, 55, 56, 57, 79	IAD-6004	Autolite	1541	91541
<b>INTERCONTINENTAL</b>							
All	4	C-26 (Continental F126, Buda 4BD-153 engine)	21, 55, 56, 57, 79	IAD-4029, 6004	Autolite	1541	91541

Year	Cyl	Model	Footnotes	Dist No.	Dist Make	IGNITOR	Ignitor II
<b>INTERNATIONAL HARVESTER</b>							
All	4	All models with IH distributors			IH	1442	
All	4	Combine (Wisconsin VRDD engine)	21, 55, 56, 57, 79	IAD-6004-2F	Autolite	1541	91541
All	4	Baler (Wisconsin VG4D, VH4D engine)	55, 56, 57, 79		Autolite	1541	91541
All	4	37T, 37 W, 47T, 47W, 57T, 57W, 71W	21, 55, 56, 57, 79	IAD-6004-2N	Autolite	1541	91541
All	4	45, 46 (Wisconsin VF4)	55, 56, 57, 79		Autolite	1541	91541
All	4	47 Twine, 47 Wire (Wisconsin VH4D, VH4)	55, 56, 57, 79		Autolite	1541	91541
All	4	56, 57 Twine & Wire (Wisconsin VH4D, VH4 engine)	79		Autolite	1541	91541
All	4	60, 70, 71 Wire (Wisconsin VG4D, VR4D engine)	55, 56, 57, 79		Autolite	1541	91541
All	4	430, T, W, 440, T, W, (Wisconsin engine.)	79		Autolite	1541	91541
All	4	C-157, C-175, C-200	55, 57, 79	IBT-4102A	Prestolite	1542	91542
All	4	574 (C-200, D-239)	55, 57, 79		Prestolite	1542	91542
All	4	544, 574, 674 (C-200, D-239)	55, 57, 79		Delco	1145A	91145A
All	4	2544 (C-200, D-239 engine)	55, 57, 79		Delco	1145A	91145A
All	4	3514 (C-153, C-175 engine)	55, 57, 79		Delco	1145A	91145A
All	4	Wisconsin VF4D engine	55, 56, 57, 79		Autolite	1541	91541
1970-71	6	UB-220, 265, UR-450, UV-450 Power Unit	56, 57, 79	1112471, 1112473	Delco	1163A	91163A
1970-73	6	H30B, F, R Payloader	56, 57, 79	1112471	Delco	1163A	91163A
All	6	80 Wisconsin VH4 engine	56, 57, 79		Autolite	1561	91561
All	6	140 Wisconsin VR4D engine	56, 57, 79	IAD series	Autolite	1561	91561
All	6	Windrower 4000 (C232, 258 engine )	79	1110523, 528	Delco	1162A	91162A
1959-64	8	UV-345, UV-549 Power Unit	79	1112755, 44, 48, 49, 82	Delco	1181	91181
<b>JOHN BEAN</b>							
1957-73	4	All Wiscon (VE4D, VE4, VF4D, VG4D, VH4D, VP4D)	21, 55, 56, 57, 79	IAD-6004	Auto/Prestolite	1541	91541
1957-73	4	E200CP, E277, G200CP	55, 56, 57, 79	IAD-4041	Auto/Prestolite	1541	91541
1958-59	4	All with (Willys F4 engine)	55, 56, 57, 79	IAD-4041	Autolite	1541	91541
1960-72	4	28E, G	55, 56, 57, 79	IAD-4041	Auto/Prestolite	1541	91541
All	4	60 (F-2 engine)	55, 56, 57, 79	IAY-4401	Autolite	1541	91541
All	4	277, E277 (F4-134 engine)	55, 56, 57, 79		Autolite	1541	91541
1958-63	6	40RC, 300G Rotomist with Chrysler Ind 32 engine	56, 57, 79	IAD-4040-1	Autolite	1561	91561
All	6	557CP (GM 305C)	56, 57, 79		Delco	1163A	91163A
All	8	700CP (GM 370)	79		Delco	1181	91181
All	8	703CP, 757CP (IHC 345 V8)	79		Delco	1181	91181
<b>JOHN BLUE</b>							
All	4	Wisconsin VH4, VH4D	21, 79	IAD-6004-2F	Autolite	1541	91541
<b>JOHN DEERE</b>							
All	4	8 Forage Harvester	21, 55, 56, 57, 79	IAD-4029	Autolite	1541	91541
All	4	72, 74 (Wisconsin VP4D engine)	55, 56, 57, 79		Autolite	1541	91541
All	4	10 Wisconsin VG4D engine	55, 56, 57, 79		Autolite	1541	91541
All	4	214WS, 216T, 216W, WS, 224T, 224WS	21, 55, 56, 57, 79	IAD-6004-2N	Autolite	1541	91541
All	4	346 (Wisconsin VG4D, VH4D engine)	21, 55, 56, 57, 79	IAD-6004-2N	Autolite	1541	91541
All	4	4020 Hercules, Wisconsin engine	55, 56, 57, 79		Autolite	1541	91541
All	4	600, 700	55, 57, 79		Autolite	1542	91542
All	4	780 (Wisconsin VG4D, VH4D engine)	55, 57, 79		Autolite	1542	91542
All	4	500, 500C	55, 57, 79	1112474, 1112648	Delco	1145A	91145A
All	4	1010, 2010 Tractors	24, 55, 56, 57, 82	X30091E	Wico	WO-141	
All	4	3010	55, 57, 79	1112623	Delco	1145A	91145A
All	4	3020	55, 57, 79	1112474, 2623, 48	Delco	1145A	91145A
All	4	Windrower 10, 14, 16 Ft.	21, 79	IAD-6004-2F	Autolite	1541	91541
All	6	55	56, 57, 79	IAD-4012A	Autolite	1561	91561
All	6	99, 299SP NP-217G, L	55, 57, 79		Auto/Prestolite	1562	91562
All	6	12 Deere EA-217 engine	55, 57, 79		Auto/Prestolite	1562	91562
All	6	95, 105	56, 57, 79	1112466	Delco	1163A	91163A
All	6	Combine 4400, 4400SP, 6602, 7700, 7700SP	56, 57, 79	1112466, 640	Delco	1163A	91163A
All	6	600, 700, 4000, 4010	56, 57, 79	1112624	Delco	1163A	91163A
All	6	4020	56, 57, 79	1112466, 624	Delco	1163A	91163A
All	6	800 Chrysler 225 engine	79		Chrysler	1361A	91361A
All	6	800 Chrysler 225 engine	56, 57, 79		Autolite	1561	91561
All	6	Harvester H-7	56, 57, 79	1112466	Delco	1163A	91163A



1247



1562

### FOOTNOTES

- 21 See page 62 for complete replacement distributors
- 23 Front mount distributor
- 24 Counter clockwise rotation
- 31 Remote mount coil conversion kit included
- 55 Also available in 6-volt negative ground, add N6 to part number
- 56 Also available in 6-volt positive ground, add P6 to part number
- 57 Also available in 12-volt positive ground, add P12 to part number
- 79 Ignitor II applications can not be used with solid core ignition wires
- 82 Will not fit magneto type distributors

Year	Cyl	Model	Footnotes	Dist No.	Dist Make	IGNITOR	Ignitor II
<b>JUMBO</b>							
All	6	B, C, E, ER, EW, HR, HW	56, 57, 79	IAD series	Autolite	1561	91561
<b>KROMER</b>							
All	4	Wisconsin VF4, VH4, VH4D	21, 55, 56, 57, 79	IAD-6004-2F	Autolite	1541	91541
<b>LILLISTON</b>							
All	4	Peanut Combine	21, 55, 56, 57, 79	IAD-6004-2F	Autolite	1541	91541
All	4	04, 1500, 2, 8 (Wisconsin VG4D, VH4, VH4D engine)	21, 55, 56, 57, 79	IAD-6004-2N	Autolite	1541	91541
<b>LONG</b>							
All	4	680 Baler Wisconsin VH4D engine	21, 55, 56, 57, 79	IAD-6004-2N	Autolite	1541	91541
All	4	A Tractor Continental F-162 engine	55, 56, 57, 79	IAD-6004-1B	Autolite	1541	91541
All	4	50, 60 Baler (Wisconsin VB4, VF4 engine)	56	IGW-4159A	Autolite	1545	
<b>LOVE</b>							
All	4	J-51 Willys CJ2A, 3 engine	55, 56, 57, 79	IAD-4008	Autolite	1541	91541
All	6	CF1, CF51, (Chrysler 5A, 6A engine)	56, 57, 79	IAD-4039, 4201	Autolite	1561	91561
<b>LUNDELL</b>							
All	4	2020 Tractor, Forage Harvester Super 606	21, 55, 56, 57, 79	IAD-6004	Autolite	1541	91541
All	6	55-17 Continental F224 engine	56, 57, 79	IAD-6002-1G	Autolite	1561	91561
<b>MASSEY FERGUSON</b>							
All	3	MF235		1112457	Delco	1131	
All	4	35SP, 72 Ft. Continental F140 engine	55, 56, 57, 79	IAD-6004-ID	Autolite	1541	91541
All	4	60, 72 Pulled Type Continental F-140 engine	55, 56, 57, 79		Autolite	1541	91541
All	4	Clipper Continental F-162 engine	55, 56, 57, 79		Autolite	1541	91541
All	4	MHF3, MHF4 (Continental engine)	55, 56, 57, 79		Autolite	1541	91541
All	4	MJA382, D (Continental engine)	55, 56, 57, 79		Autolite	1541	91541
All	4	11 Pony, 16 Pacer, 21 Colt, 22K, 23K, 23	55, 56, 57, 79		Autolite	1541	91541
All	4	Mustang, 30, K, 33, 44 (Continental engine)	55, 56, 57, 79		Autolite	1541	91541
All	4	55 Continental J-382 engine	55, 56, 57, 79		Autolite	1541	91541
All	4	333, RT, RS, HA, 444, 555 (Continental engine)	55, 56, 57, 79		Autolite	1541	91541
All	4	50 Wisconsin VF4 engine	56	IGW-4150, 4151	Autolite	1545	
All	4	Clipper 6 ft., 7 ft. (Wisconsin VF4 engine)	56		Autolite	1545	
All	4	MF20 Wisconsin VF4 engine	56	IGW-4159A	Autolite	1545	
All	4	F40 Continental Z-134 engine	55, 57, 79	1112643	Delco	1145A	91145A
All	4	H-260 Continental H-260 engine	55, 57, 79		Delco	1145A	91145A
All	4	MF Special 35, MF50 (Continental Z-134 engine)	55, 57, 79	1112643	Delco	1145A	91145A
All	4	MF65 Continental G-176 engine	55, 57, 79	1112643, 644	Delco	1145A	91145A
All	4	MF-135, MF-150, MF-165	55, 57, 79	1112643, 644	Delco	1145A	91145A
All	4	MF-175, MF-180	55, 57, 79	1112647, 693	Delco	1145A	91145A
All	4	MF-2135, MF2200, MF2500, MF-3165	55, 57, 79	1112644	Delco	1145A	91145A
All	4	MF255, 265	55, 57, 79	1112458, 693	Delco	1145A	91145A
All	4	MF285 Perkins AG4-263 engine	55, 57, 79	1112693	Delco	1145A	91145A
All	4	MF-6500	55, 57, 79	1112693	Delco	1145A	91145A
All	4	Swather MF-36	57, 79	1112448, 478	Delco	1146A	91146A
All	6	Combine (Chrysler 5, 5A, 30, 251 engine)	56, 57, 79	IAD-4039-1	Autolite	1561	91561
All	6	27 (Chrysler 8A, 30, 251, 265 engine)	56, 57, 79	IAD-4040-1	Autolite	1561	91561
All	6	60SP, 70, 72SP, 80SP, 82SP, (Chrysler 5, 30, 251)	56, 57, 79	IAD-4039-1	Autolite	1561	91561
All	6	90SP, 92 (Chrysler 8A, 30, 251, 265 engine)	56, 57, 79	IAD-4040-1	Autolite	1561	91561
All	6	Clipper Forager Continental F-226 engine	56, 57, 79		Autolite	1561	91561
All	6	44-6 Continental F-226 engine	56, 57, 79		Autolite	1561	91561
All	6	MF410 GMC 292	56, 57, 79		Delco	1163A	91163A
All	6	MF-1100, MF-1105 (gas and LPG engine)	56, 57, 79	1112687, 696	Delco	1163A	91163A
All	6	MF-410-292 engine	56, 57, 79	1112479, 640	Delco	1163A	91163A
<b>MINNEAPOLIS-MOLINE</b>							
All	4	Combine G12.	21, 55, 56, 57, 79	IAD-6004-2F	Autolite	1541	91541
All	4	69, 88 Wisconsin VE4 engine	55, 56, 57, 79		Autolite	1541	91541
All	4	A (Hercules IX43, B3, K3, engine)	55, 56, 57, 79		Autolite	1541	91541
All	4	V ZXB-3 engine	55, 56, 57, 79		Autolite	1541	91541
All	4	Windrower	21, 55, 56, 57, 79	IAD-6004-2F	Autolite	1541	91541
All	4	G900, 1000	55, 57, 79	1112684	Delco	1145A	91145A
All	4	Jet Star 3, 4 Star, 4 Star Super, 5 Star	55, 57, 79	1112642	Delco	1145A	91145A
All	4	U302 (206B-4, 220A4, 220-4 engine)	55, 57, 79		Delco	1145A	91145A
All	4	M670, U-302	55, 57, 79	1112642	Delco	1145A	91145A
All	4	M670, U-302	57, 79	1112660	Delco	1146A	91146A
All	4	100, 101	21, 55, 56, 57, 79	IAD-6004-2N	Autolite	1541	91541
All	6	2890, 3490, 3496, 4290, 4292, 4293, 4296, 5297	56, 57, 79	IAD-4040-1	Autolite	1561	91561
All	6	G-704	56, 57, 79	1112662, 84	Delco	1163A	91163A
All	6	G-1000, G-1050, G-1350,	30, 56, 57, 79		Delco	1163A	91163A
<b>MOTEC</b>							
All	4	G-12	21, 55, 56, 57, 79	IAD-6004-2F	Autolite	1541	91541
All	4	M5	55, 57, 79	IBT-4001G	Prestolite	1542	91542





### PLUG 'N PLAY BILLET DISTRIBUTORS

Plug n' Play billet distributors are designed for maximum ignition performance at a price you can afford. Our distributors are available with Ignitor II technology, or the all NEW Ignitor III multi-spark rev limiting modules. Replace your outdated points, electronic distributor or bulky HEIs with this performance proven system. Simply install the distributor in the engine, connect two wires and start it up!

For even more performance, consider adding one of our compatible Flame-Thrower coils for increased spark energy and higher RPM potential. The lineup includes the Flame-Thrower II and Flame-Thrower III canister style coils as well as our New HC and HV E-core style coils. Specific application information can be found in the coil section of this catalog.

#### FEATURES

- Precision CNC machined 6061-T6 billet aluminum housings are lightweight yet offer maximum strength.
- Each billet distributor is hand polished and buffed to a high luster.
- Tempered distributor shaft has low torsion displacement for accurate timing and extended operational life.
- Upper ball bearing and extra long oil impregnated bronze lower bushing work together to reduce friction and provide shaft and advance mechanism stability reducing high RPM vibration.
- Precision stamped and balanced mechanical advance weights eliminate erratic timing.
- Adjustable mechanical advance with proprietary limiting function permits multiple settings. Distributors are factory set with a performance advance curve and are provided with additional springs for custom advance curves.
- High dielectric strength cap with male or female brass terminals and premium rotor with brass contact.
- Warranty: 30 Months electronics / Limited 1 year mechanical.
- Legal in all 50 states and Canada.  
( C.A.R.B. E.O. #D-57-23)\*

\* Non vacuum advance distributors do not have an E.O. number and are not legal for sale or use on pollution controlled motor vehicles.



### Ignitor® III EQUIPPED BILLET DISTRIBUTORS

#### FEATURES

- Multiple sparks thru the entire RPM range.
- Integrated digital REV limiter with LED feedback for precise RPM setting.
- Memory safe function stores settings eliminating unintended changes to Rev limit.
- Adaptive dwell maintains peak energy throughout the entire RPM range, reducing misfires while improving engine performance.
- Peak current level is reached just prior to spark for maximum energy without heat build-up, increasing coil performance and module reliability.
- Adjusts spark timing at higher RPMs to compensate for the inherent electronic delay.
- Senses startup and increases energy for quicker, easier starting.
- Thermal clad surface mount construction for superior reliability.
- Built-in reverse polarity and over current protection shuts down the system, preventing component damage.
- Not compatible with CD or Multi-Spark boxes.

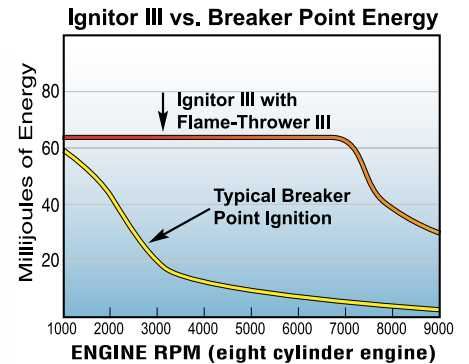

FLAME-THROWER DISTRIBUTORS

Description	Footnotes	Distributor Part Numbers			
<b>AMC 290, 304, 343, 360, 390, 401 ENGINES</b>					
Ignitor III distributor with vacuum advance	76	D7160700	D7160701	D7160710	D7160711
Ignitor III distributor without vacuum advance	75, 76	D7160800	D7160801	D7160810	D7160811
<b>BUICK 400, 430, 455 ENGINES</b>					
Ignitor III distributor with vacuum advance	76, 78	D7150700	D7150701	D7150710	D7150711
Ignitor III distributor without vacuum advance	75, 76, 78	D7150800	D7150801	D7150810	D7150811
<b>CHEVROLET SMALL BLOCK - BIG BLOCK ENGINES</b>					
Ignitor III distributor with vacuum advance	76, 89	D7100700	D7100701	D7100710	D7100711
Ignitor III distributor without vacuum advance	75, 76, 89	D7100800	D7100801	D7100810	D7100811
Ignitor III slip collar distributor without vacuum advance	75, 76, 87, 89			D7105810	D7105811
<b>CHEVROLET 348, 409 ENGINES</b>					
Ignitor III distributor with vacuum advance	76, 89	D7101700	D7101701	D7101710	D7101711
Ignitor III distributor without vacuum advance	75, 76, 89	D7101800	D7101801	D7101810	D7101811
<b>CHRYSLER 273, 318, 340 &amp; 360 ENGINES</b>					
Ignitor III distributor with vacuum advance	76	D7141700	D7141701	D7141710	D7141711
Ignitor III distributor without vacuum advance	75, 76	D7141800	D7141801	D7141810	D7141811
<b>CHRYSLER 383 &amp; 400 ENGINES</b>					
Ignitor III distributor with vacuum advance	76	D7142700	D7142701	D7142710	D7142711
Ignitor III distributor without vacuum advance	75, 76	D7142800	D7142801	D7142810	D7142811
<b>CHRYSLER 413, 426 &amp; 440 (INCLUDING HEMI) ENGINES</b>					
Ignitor III distributor with vacuum advance	73, 74, 76	D7143700	D7143701	D7143710	D7143711
Ignitor III distributor without vacuum advance	73, 74, 75, 76	D7143800	D7143801	D7143810	D7143811

#### FOOTNOTES

- 73 Do to variances in 440 cylinder head castings, some cylinder heads may require grinding for adequate distributor clearance
- 74 Will not fit wedge engines with aftermarket heads
- 75 Non vacuum advance distributors do not have an E.O. number and are not legal for sale or use on pollution controlled motor vehicles
- 76 Can not be used with solid core ignition wires
- 78 Will not clear factory Grand Sport Ram Air cleaner
- 87 Slip collar distributor allows adjustment of installed height for non standard deck engines
- 89 Bronze distributor gears available see page 38



### EQUIPPED BILLET DISTRIBUTORS



Description	Footnotes				
<b>FORD 221, 260, 289 &amp; 302 (EXCLUDING 5.0L) ENGINES</b>					
Ignitor III distributor with vacuum advance	76, 89	D7130700	D7130701	D7130710	D7130711
Ignitor III distributor without vacuum advance	75, 76, 89	D7130800	D7130801	D7130810	D7130811
<b>FORD 351W ENGINES</b>					
Ignitor III distributor with vacuum advance	76, 89	D7131700	D7131701	D7131710	D7131711
Ignitor III distributor without vacuum advance	75, 76, 89	D7131800	D7131801	D7131810	D7131811
<b>FORD FE 352, 360, 390, 427, 428 ENGINES</b>					
Ignitor III distributor with vacuum advance	76, 89	D7133700	D7133701	D7133710	D7133711
Ignitor III distributor without vacuum advance	75, 76, 89	D7133800	D7133801	D7133810	D7133811
<b>FORD 351C, 351M, 400, 429 &amp; 460 ENGINES</b>					
Ignitor III distributor with vacuum advance	76, 89	D7132700	D7132701	D7132710	D7132711
Ignitor III distributor without vacuum advance	75, 76, 89	D7132800	D7132801	D7132810	D7132811
<b>OLDSMOBILE 260, 307, 330, 350, 400, 403, 425, 455 ENGINES</b>					
Ignitor III distributor with vacuum advance	76	D7110700	D7110701	D7110710	D7110711
Ignitor III distributor without vacuum advance	75, 76	D7110800	D7110801	D7110810	D7110811
<b>PONTIAC 301, 326, 350, 389, 400, 421, 428, 455 ENGINES</b>					
Ignitor III distributor with vacuum advance	76	D7120700	D7120701	D7120710	D7120711
Ignitor III distributor without vacuum advance	75, 76	D7120800	D7120801	D7120810	D7120811

FLAME-THROWER DISTRIBUTORS



**D7100711  
CHEVROLET  
SMALL BLOCK**



**D7130711  
FORD  
SMALL BLOCK**



**D7140711  
CHRYSLER  
SMALL BLOCK**



**D7150711  
BUICK BIG BLOCK**



**D7120711  
PONTIAC V8**



**D7110711  
OLDSMOBILE V8**

# Ignitor® II EQUIPPED BILLET DISTRIBUTORS

### FEATURES

- Integrated patented Ignitor II technology with a powerful micro controller and adaptive dwell algorithms constantly adjust the dwell angle to maintain peak energy throughout the entire RPM range for increased high and low RPM performance.
- Cobalt magnets and Hall Effect trigger for stable timing and precise spark distribution.
- Compensates for inherent electronic delay by adjusting the spark timing throughout the entire RPM range.
- Synchronized peak current and spark timing reduces heat build-up.
- Compatible with most Capacitive Discharge Systems.
- Warranty: 30 months electronics / Limited 1 year mechanical.

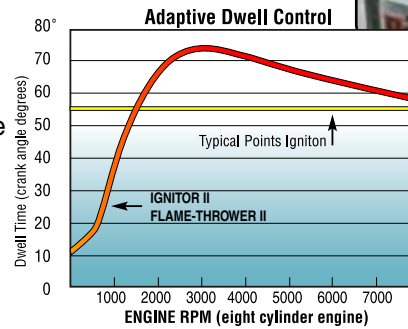

Description	Footnotes				
<b>AMC 290, 304, 343, 360, 390, 401 ENGINES</b>					
Ignitor II distributor with vacuum advance	76	D160700	D160701	D160710	D160711
Ignitor II distributor without vacuum advance	75, 76	D160800	D160801	D160810	D160811
<b>BUICK 400, 430, 455 ENGINES</b>					
Ignitor II distributor with vacuum advance	76, 78	D150700	D150701	D150710	D150711
Ignitor II distributor without vacuum advance	75, 76, 78	D150800	D150801	D150810	D150811
<b>CHEVROLET SMALL BLOCK - BIG BLOCK ENGINES</b>					
Ignitor II distributor with vacuum advance	76, 89	D100700	D100701	D100710	D100711
Ignitor II distributor without vacuum advance	75, 76, 89	D100800	D100801	D100810	D100811
Ignitor II non-vacuum advance distributor w/slip collar	75, 76, 87, 89			D105810	D105811
<b>CHEVROLET 348, 409 ENGINES</b>					
Ignitor II distributor with vacuum advance	76, 89	D101700	D101701	D101710	D101711
Ignitor II distributor without vacuum advance	75, 76, 89	D101800	D101801	D101810	D101811
<b>CHEVROLET 90 DEGREE V6 ENGINES</b>					
Ignitor II distributor with vacuum advance	76, 89	D107700	D107701	-----	-----
Ignitor II distributor without vacuum advance	75, 76, 89	D107800	D107801	-----	-----
<b>CHRYSLER 273, 318, 340 &amp; 360 ENGINES</b>					
Ignitor II distributor with vacuum advance	76	D141700	D141701	D141710	D141711
Ignitor II distributor without vacuum advance	75, 76	D141800	D141801	D141810	D141811
<b>CHRYSLER 383 &amp; 400 ENGINES</b>					
Ignitor II distributor with vacuum advance	76	D142700	D142701	D142710	D142711
Ignitor II distributor without vacuum advance	75, 76	D142800	D142801	D142810	D142811
<b>CHRYSLER 413, 426 &amp; 440 (INCLUDING HEMI) ENGINES</b>					
Ignitor II distributor with vacuum advance	73, 74, 76	D143700	D143701	D143710	D143711
Ignitor II distributor without vacuum advance	73, 74, 75, 76	D143800	D143801	D143810	D143811



D160711  
AMC V8



D106701  
GM L6

New applications appear in red

### FOOTNOTES

- 73 Do to variances in 440 cylinder head castings, some cylinder heads may require grinding for adequate distributor clearance
- 74 Will not fit wedge engines with aftermarket heads
- 75 Non vacuum advance distributors do not have an E.O. number and are not legal for sale or use on pollution controlled motor vehicles
- 76 Can not be used with solid core ignition wires
- 78 Will not clear factory Grand Sport Ram Air air cleaner
- 87 Slip collar distributor allows adjustment of installed height for non standard deck engines
- 89 Bronze distributor gears available see page 38

# Ignitor® II EQUIPPED BILLET DISTRIBUTORS



Description	Footnotes				
<b>FORD 221, 260, 289 &amp; 302 (EXCLUDING 5.0L) ENGINES</b>					
Ignitor II distributor with vacuum advance	76, 89	D130700	D130701	D130710	D130711
Ignitor II distributor without vacuum advance	75, 76, 89	D130800	D130801	D130810	D130811
<b>FORD 351W ENGINES</b>					
Ignitor II distributor with vacuum advance	76, 89	D131700	D131701	D131710	D131711
Ignitor II distributor without vacuum advance	75, 76, 89	D131800	D131801	D131810	D131811
<b>FORD FE 352, 360, 390, 427, 428 ENGINES</b>					
Ignitor II distributor with vacuum advance	76, 89	D133700	D133701	D133710	D133711
Ignitor II distributor without vacuum advance	75, 76, 89	D133800	D133801	D133810	D133811
<b>FORD 351C, 351M, 400, 429 &amp; 460 ENGINES</b>					
Ignitor II distributor with vacuum advance	76, 89	D132700	D132701	D132710	D132711
Ignitor II distributor without vacuum advance	75, 76, 89	D132800	D132801	D132810	D132811
<b>GM L6 ENGINES</b>					
Ignitor II distributor with vacuum advance	76	D106700	D106701		
Ignitor II distributor without vacuum advance	75, 76	D106800	D106801		
<b>OLDSMOBILE 260, 307, 330, 350, 400, 403, 425, 455 ENGINES</b>					
Ignitor II distributor with vacuum advance	76	D110700	D110701	D110710	D110711
Ignitor II distributor without vacuum advance	75, 76	D110800	D110801	D110810	D110811
<b>PONTIAC 301, 326, 350, 389, 400, 421, 428, 455 ENGINES</b>					
Ignitor II distributor with vacuum advance	76	D120700	D120701	D120710	D120711
Ignitor II distributor without vacuum advance	75, 76	D120800	D120801	D120810	D120811
<b>VOLKSWAGEN TYPE I ENGINES</b>				<b>Black</b>	<b>Grey</b>
VW billet distributors are available with the performance proven Ignitor II ignition or for those on a budget the original Ignitor ignition.					
Ignitor II distributor without vacuum advance	75, 76, 77			D180810	D180813
Ignitor distributor without vacuum advance	75, 77			D186810	D186813

New applications appear in red



**CHEVROLET**  
348-409  
D101811



**FORD FE**  
D133710



**CHRYSLER**  
383-400  
D142801



**BUICK**  
BIG BLOCK  
D150711



**PONTIAC V8**  
D120711



**VW TYPE I**  
D180810

### MAGNETIC TRIGGER BILLET DISTRIBUTORS

Magnetic triggered billet distributors are built using the same great platform we use for our plug n' play distributor series. These feature rich distributors are the perfect alternative to the more expensive distributors competitors offer.

#### FEATURES

- Precision magnetic pickup coil and reluctor offer extremely accurate signaling at low and high RPM.
- Specially engineered reluctor made from lightweight FC-0208 alloy offers superior dimensional stability for symmetrical spark separation.
- Overmolded magnetic pickup coil supports windings while providing excellent resistance to corrosion.
- Easy wiring with standard Tyco Mate-N-Lok™ connector works with most ignition system harnesses.
- Compatible with most capacitive discharge ignition boxes.
- Limited One Year Warranty.



Description	Footnotes		
<b>CHEVROLET SMALL BLOCK - BIG BLOCK ENGINES</b>			
Magnetic Trigger distributor without vacuum advance	75, 81, 89	D300810	D300811
Magnetic Trigger slip collar distributor without vacuum advance	75, 81, 87, 89	D305810	D305811

### BILLET DISTRIBUTOR DIMENSIONS

Flame-Thrower billet distributors are frequently used in tight engine compartments due to their simple design and relatively small size. The chart below details approximate distributor dimensions for each engine family. The height dimension "A" is taken from the installed surface to the highest point on the distributor cap. Although our distributors fit their intended engine application, each vehicle application must be evaluated independently to insure adequate space for distributor fitment as well as air cleaner and hood clearance.

Description	Dim A	Cap		Gear I.D.
		Female Cap Dim B	Male Cap Dim B	
AMC engines	5"	8.52"	9.24"	0.5"
Buick engines	5"	8.29"	8.92"	0.5"
Ford 289-302 engines	5"	7.77"	8.49"	0.467"
Ford 351W engines	5"	8.60"	9.32"	0.5"
Ford 351C, 351M, 400, 429 & 460 engines	5"	8.60"	9.32"	0.5"
Ford 332, 352, 360, 390, 406, 410, 427, 428 FE engines	5"	8.41"	9.13"	0.5"
Chevrolet small & big block engines	5"	7.66"	8.38"	0.5"
Chevrolet 90 degree V6 engines	5"	7.66"	N/A	0.5"
Chrysler 273, 318, 340 & 360 engines	5"	7.82"	8.54"	N/A
Chrysler 383 & 400 engines	5"	7.80"	8.52"	N/A
Chrysler 413, 426 & 440 (Including Hemi) engines	5"	7.80"	8.52"	N/A
GM L6 engines	5"	7.66"	N/A	0.486"
Oldsmobile 260, 307, 330, 350, 400, 403, 425, 455 engines	5"	8.64"	9.36"	0.5"
Pontiac 326, 350, 389, 400, 421, 428, 455 engines	5"	8.39"	9.11"	0.5"
Volkswagen Type I engines	4.625"	N/A	5.5"	0.5"

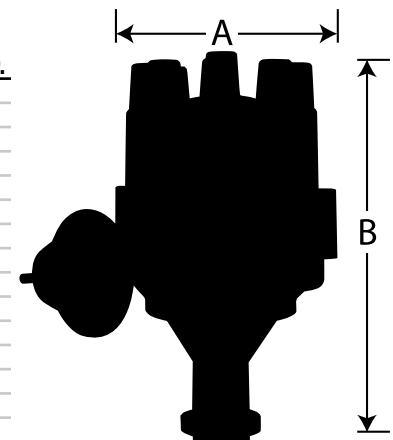

#### FOOTNOTES

- |  |  |
|--|--|
| 75 Non vacuum advance distributors do not have an E.O. number and are not legal for sale or use on pollution controlled motor vehicles | 87 Slip collar distributor allows adjustment of installed height for non standard deck engines |
| 76 Can not be used with solid core ignition wires  | 89 Bronze distributor gears available see page 38  |
| 77 Distributor has male terminal distributor cap which requires different ignition wire terminals and boots                            |  |
| 78 Will not clear factory Grand Sport Ram Air air cleaner  |  |
| 81 Must be use with ignition box   |  |

New applications appear in red



D600700



D654713



**Description**

<b>DISTRIBUTOR CAPS</b>				
Replacement distributor cap for 8 cylinder Flame-Thrower billet distributors	D650700	D650701	D650710	D650711
Replacement distributor cap for 6 cylinder Flame-Thrower billet distributors	D656700	D656701	-----	-----
Replacement distributor cap for 4 cylinder Flame-Thrower billet distributors	-----	-----	D654710	-----
Replacement distributor cap for 4 cylinder Flame-Thrower billet distributors (Light Grey Color)	-----	-----	D654713	-----
<b>DISTRIBUTOR CAP AND ROTOR KITS</b>				
Cap and rotor for 8 cylinder Flame-Thrower billet distributors	D600700	D600701	D600710	D600711
Cap and rotor for 6 cylinder Flame-Thrower billet distributors	D606700	D606701	-----	-----
Cap and rotor for 4 cylinder Flame-Thrower billet distributors	-----	-----	D604710	-----
Cap and rotor for 4 cylinder Flame-Thrower billet distributors (Light Grey Color)	-----	-----	D604713	-----

**UPGRADE / REPLACEMENT MODULES**

Upgrade / Replacement Ignitor III module for 8 cylinder Flame-Thrower billet distributors	D7500700
Replacement Ignitor II module for all Flame-Thrower billet distributors	D500700
Replacement Ignitor module for D186810 and D186813 distributors	D500706

**DISTRIBUTOR ROTOR**

Replacement rotor for all Flame-Thrower billet distributors	D660701
---	---------

**VACUUM CANISTER**

Vacuum canister for all Flame-Thrower billet distributors	D701700
---	---------

**VACUUM LOCKOUT**

Vacuum lockout for all clockwise rotating Flame-Thrower billet distributors	D702700
Vacuum lockout for all counter clockwise rotating Flame-Thrower billet distributors	D703700

**ADVANCE SPRING KIT**

Performance mechanical advance springs	D700700
--	---------

**BRONZE DISTRIBUTOR GEARS**

Bronze gear Chevrolet 90° V6, SB, BB, 348-409 (0.5" shaft)	D671001
Bronze gear Ford 289-302 (0.467" shaft)	D671301
Bronze gear Ford 351W (0.5" shaft)	D671302
Bronze gear Ford 351C, 351M, 400, 429 & 460 (0.5" shaft)	D671303
Bronze gear Ford FE 352, 360, 390, 427, 428 (0.5" shaft)	D671303

Now you can upgrade your standard Ignitor II equipped billet distributor to the new Ignitor III featuring multiple spark output and integrated rev limiter.



D7500700



D500700

**NEW**



D671001

D671301



D671302

D671303



D700700



D702700



D701700



# Ignitor® II **EQUIPPED MARINE BILLET DISTRIBUTORS**

Our Flame-Thrower marine billet distributors share many of the performance features that you find in our automotive versions. Marine approved distributors are designed to meet or exceed SAE J1171 standards.

## FEATURES

- Integrated patented Ignitor II technology with adaptive dwell control.
- Non-vented distributor cap with stainless steel fasteners keeps the distributor cap firmly in place.
- Triple screen spark arrestor offers added protection.
- Warranty: 30 months electronics / limited 1 year mechanical.



FLAME-THROWER DISTRIBUTORS

Description				
<b>CHEVROLET SMALL BLOCK - BIG BLOCK ENGINES</b>				
Ignitor II marine distributor	D200800	D200801	D200810	D200811
Ignitor II marine distributor opposite rotation engines	D209800	D209801		
<b>CHRYSLER 273, 318, 340 &amp; 360</b>				
Ignitor II marine distributor	D241800	D241801		
<b>FORD 221, 260, 289 &amp; 302 (EXCLUDING 5.0L) ENGINES</b>				
Ignitor II marine distributor	D230800	D230801		
<b>FORD 351W ENGINES</b>				
Ignitor II marine distributor	D231800	D231801		
<b>FORD 351C, 351M, 400, 429 &amp; 460 ENGINES</b>				
Ignitor II marine distributor	D232800	D232801		

New applications appear in red

## MARINE PARTS AND ACCESSORIES

Marine distributor caps are non vented caps with specially designed stainless steel hardware.

<b>MARINE DISTRIBUTOR CAPS</b>	
Black cap with female terminals	D651700
Red cap with female terminals	D651701
Black cap with male terminals	D651710
Red cap with male terminals	D651711
<b>DISTRIBUTOR ROTOR</b>	
Replacement rotor for all marine Flame-Thrower billet distributors	D660701



D651701

Some marine applications are equipped with dual engines. These applications generally have one engine which rotates in the opposite direction and require a specialized reverse cut distributor gear. Our high quality steel gears are designed specifically for marine Plug n' Play billet distributors and are precision ground to provide the perfect distributor to cam mesh

<b>DISTRIBUTOR GEARS</b>	
Steel distributor gear for Chevrolet 90° V6, SB and BB opposite rotation engines.	D671002

**NEW**



D671002

New applications appear in red

### HIGH PERFORMANCE DISTRIBUTORS

Flame-Thrower HP distributors take the performance line of distributors one step higher. That's right, HP stands for High Performance, and that's what you get with our all new HP distributors. These distributors feature patented Ignitor II technology and are available with top exit or our new side exit caps. For optimal performance, use our Flame-Thrower II 45,000 volt coils.



#### FEATURES

- All new lightweight cast aluminum housings.
- Tailored advance curve for optimal performance and drivability.
- Integrated Ignitor II electronic ignition with variable dwell maintains peak energy throughout the entire RPM range, reducing misfires while improving engine performance.
- Develops on average 4 times more available energy between 3000 and 5000 RPM, and 2 times more available plug voltage.
- Peak current level is reached just prior to spark for maximum energy without the heat build-up, increasing coil and module life.
- Adjusts spark timing at higher RPMs to compensate for the inherent electronic delay.
- Senses startup and develops more energy for quicker, easier starting.
- Built in reverse polarity and over current protection shuts down the system, preventing component damage.
- High dielectric strength cap with brass terminals.
- Top or side exit caps available.
- Balanced rotor with overmolded brass contact.
- Warranty: 30 months electronics / limited 1 year mechanical.
- Not legal for sale or use on pollution controlled motor vehicles.

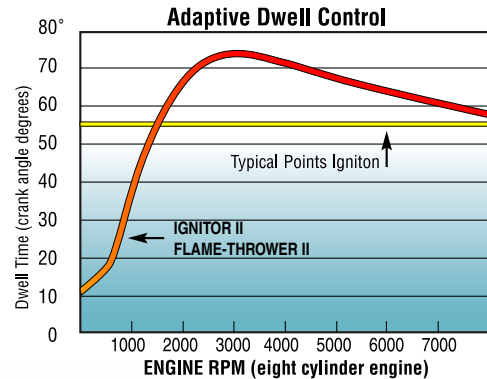

FLAME-THROWER DISTRIBUTORS



Description	Top Exit	Side Exit
<b>ENGLISH FORD &amp; LOTUS TWIN CAM</b>		
Performance distributor with vacuum advance	D190600	D190609
Performance distributor without vacuum advance	D190500	D190509
<b>BMC A &amp; B SERIES 4 CYLINDER ENGINES</b>		
Performance distributor without vacuum advance	D170600	D170609
<b>BMC 6 CYLINDER ENGINES</b>		
Performance distributor without vacuum advance	D171600	

#### SERVICE PARTS

Our caps are made from hi-performance 60 KV rated alkyl molding compound for superior protection from "arc-thru" and cross-fire. Rotors feature brass contacts and are overmolded for durability.

Description	Part No.
<b>SERVICE PARTS</b>	
Cap and rotor kit 4 cylinder top exit cap	D604600
Cap and rotor kit 4 cylinder side exit cap	D604609
Cap and rotor kit 6 cylinder top exit cap	D606600
Top exit distributor cap 4 cylinder	D654600
Side exit distributor cap 4 cylinder	D654609
Top exit distributor cap 6 cylinder	D656600
Rotor	D660702
Ignitor II module	D500701



**PERFORMANCE DISTRIBUTORS FOR BRITISH ENGINES**

Replace your worn out Lucas 23D, 25D or 45D distributor with a distributor that will deliver the performance you demand. Our Flame-Thrower performance distributors use all new castings modeled after the original Lucas 45D distributor. Each distributor is then precision machined for an exact fit. Four cylinder applications are available with top or our new side exit caps.

**FEATURES**

- All new lightweight cast aluminum housings.
- Tailored advance curve for optimal performance and drivability.
- Integrated Ignitor electronic ignition delivers twice the voltage to the spark plugs, increasing horsepower, fuel economy, and spark plug life.
- Rotating cobalt magnets trigger a Hall Effect integrated circuit which enables precise timing.
- High dielectric strength cap with brass terminals.
- Balanced rotor with overmolded brass contact.
- Top or side exit caps available.
- Available for 12-volt negative and positive ground systems.
- Warranty: 30 months electronics / limited 1 year mechanical.
- Not legal for sale or use on pollution controlled motor vehicles.

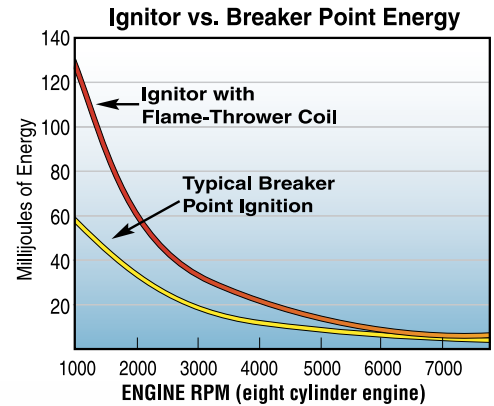

Description	Top Exit	Side Exit
<b>BMC A &amp; B SERIES 4 CYLINDER ENGINES</b>		
Performance distributor with vacuum advance (12v NEG)	D176600	D176609
Performance distributor with vacuum advance (12v POS)	D178600	D178609
<b>BMC 6 CYLINDER ENGINES</b>		
Performance distributor with vacuum advance (12v NEG)	D177600	
Performance distributor with vacuum advance (12v POS)	D179600	



**SERVICE PARTS**

Our caps are made from hi-performance 60 KV rated alkyl molding compound for superior protection from "arc-thru" and cross-fire. Rotors feature brass contacts and are overmolded for durability.

Description	Part No.
<b>SERVICE PARTS</b>	
Cap and rotor kit 4 cylinder top exit cap	D604600
Cap and rotor kit 4 cylinder side exit cap	D604609
Cap and rotor kit 6 cylinder top exit cap	D606600
Top exit distributor cap 4 cylinder	D654600
Side exit distributor cap 4 cylinder	D654609
Top exit distributor cap 6 cylinder	D656600
Rotor	D660702
Module 12 volt negative ground	D500707
Module 12 volt positive ground	D500708



D660702



D654609

**NEW**

D176609

FLAME-THROWER DISTRIBUTORS

New applications appear in red

### PERFORMANCE DISTRIBUTORS FOR VW TYPE I ENGINES

Now you can get a quality distributor that delivers excellent performance and doesn't break the bank. We've taken all the features that you like about the Bosch 009 distributor, and the performance capabilities of the 010 and 050 distributor and designed them into our Flame-Thrower mechanical advance distributor. The vacuum advance version also has a custom tailored advance curve to suit most applications. To top things off these distributors feature integrated Ignitor electronics for both 12 and 6 Volt negative ground systems.



FLAME-THROWER DISTRIBUTORS

#### FEATURES

- All new lightweight cast aluminum housings.
- Tailored advance curve for optimal performance and driveability.
- Integrated Ignitor electronic ignition delivers twice the voltage to the spark plugs, increasing horsepower, fuel economy, and spark plug life.
- Rotating cobalt magnets trigger a Hall Effect integrated circuit which enables precise timing.
- High dielectric strength cap with brass terminals.
- Balanced rotor with low resistance brass contact.
- Available for 12-volt and 6-Volt negative ground systems.
- Warranty: 30 months electronics / limited 1 year mechanical.
- Not legal for sale or use on pollution controlled motor vehicles.

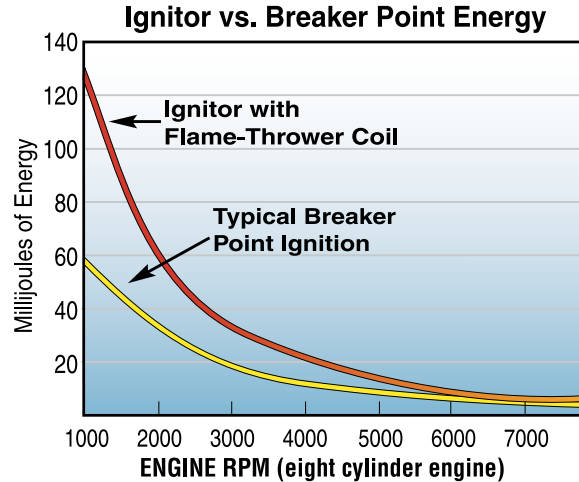

D186504



D186604

Description	Part No.
<b>VW TYPE I ENGINES</b>	
Performance distributor with vacuum advance (12v NEG)	D186504
Performance distributor without vacuum advance (12v NEG)	D186604
Performance distributor with vacuum advance (6v NEG)	D189504
Performance distributor without vacuum advance (6v NEG)	D189604
<b>SERVICE PARTS</b>	
Cap and rotor kit	D604604
Distributor cap	D654604
Rotor	D660703
Module 12 volt negative ground for dist. D186604	D500709
Module 12 volt negative ground for dist. D186504	D500711
Module 6 volt negative ground for dist. D189604	D500710
Module 6 volt negative ground for dist. D189504	D500712



D604604

## PERFORMANCE DISTRIBUTOR FOR ROVER V8 ENGINES

Replace your worn out Lucas 35D distributor with a distributor that will deliver the performance you demand. Our Flame-Thrower performance distributors are the perfect solution for rover V8 engine swaps. Integrated Ignitor technology increases energy levels and provides maintenance free operation. Installation is simple with only two wires to attach. These distributors are made from all new castings modeled after the original Lucas 35D distributor. Each distributor is then precision machined for an exact fit.



### FEATURES

- All new lightweight cast aluminum housings.
- Integrated Ignitor electronic ignition delivers twice the voltage to the spark plugs, increasing horsepower, fuel economy, and spark plug life.
- Rotating cobalt magnets trigger a Hall Effect integrated circuit which enables precise timing.
- High dielectric strength cap.
- Balanced rotor with overmolded brass contact.
- Warranty: 30 months electronics / limited 1 year mechanical.
- Not legal for sale or use on pollution controlled motor vehicles.



FLAME-THROWER DISTRIBUTORS

#### Part No.

ROVER V8 ENGINES	
1976-later (flex shaft) Ignitor equipped performance distributor w/vacuum	D175510

## OE REPLACEMENT DISTRIBUTOR FOR ROVER V8 ENGINES

This OE replacement distributor offers an economical alternative to the expensive factory Lucas 35DLM distributor. Fits 92-95 3.5L, 3.9L and 4.2L engines with two pin ignition modules.



#### Part No.

ROVER V8 ENGINES	
Late model 35DLM series 2 pin replacement distributor w/vacuum	D175520

## SERVICE PARTS

SERVICE PARTS		Part No.
Cap and rotor kit		D608600
Distributor cap		D658600
Rotor		D660704
Ignitor Module 12 volt negative ground		D500713
OE style Module		D500714



### STREET / STRIP HEI DISTRIBUTORS

Our HEI distributors are built from the ground up with all new components. We have engineered a special high energy module and coil combination that operates without misfires beyond 7500 RPM. That's nearly 3000 RPM higher than most stock HEI distributors.

Flame-Thrower HEI distributor produce 67% more energy with a 45% faster spark breakdown time when compared to the stock HEI. This means twice the energy to the spark plugs. Our tests show that with these improvements wider plug gaps can be used resulting in an increasing flame kernel growth for more efficient combustion.

#### FEATURES

- New lightweight aluminum alloy housing.
- Aligned and honed high quality bronze sintered bushings for reduced friction and extended life.
- Centerless ground corrosion resistant shaft reduces friction and provides concentric operation.
- Distributor gear is ground to exact tolerances for tighter mesh with camshaft. (Bronze distributor gear available)
- High dielectric strength cap with brass terminals and low resistance center coil brush.
- Balanced rotor with nylon screws prevent arcing and reduce vibration at high RPMs.
- Adjustable vacuum advance canister and high performance advance curve.
- Precision machined chromoly advance weights and center plate eliminate erratic timing.
- Meets stringent automobile susceptibility, vibration and shock requirements.
- Legal in all 50 states and Canada (C.A.R.B. E.O. #D-57-23)
- Limited One Year Warranty.



#### Description

CHEVROLET SB & BB (STANDARD DECK HEIGHT)			
Cast finish	D1000	D1001	D1002
Machine polished	D1050	D1051	D1052
1987-95 EST equipped cars and trucks (Computer controlled engines)	D1020	D1021	
FORD 221, 260, 289 & 302 (EXCLUDES '84 AND LATER 5.0L)			
Machine polished	D1350	-----	D1352
OLDSMOBILE 260, 307, 330, 350, 400, 403 & 455			
Cast finish	D1100	D1101	D1102
PONTIAC 301, 326, 350, 389, 400, 421, 428 & 455			
Cast finish	D1200	D1201	D1202
SERVICE PARTS			
Replacement HEI cap	D4050	D4051	D4052
Replacement HEI rotor		D4061	D4062
Replacement EST cap	D4150	D4151	-----
Replacement EST rotor	D4260	-----	-----

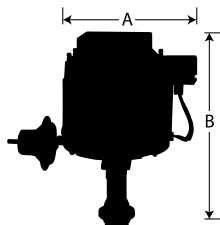

Description	Dim A	Dim B
Chevrolet small & big block engines	6.295"	7.5"
Chevrolet small & big block engines EST distributor	4.5"	7"
Ford 289-302 engines	6.295"	9.5"
Oldsmobile 260, 307, 330, 350, 400, 403, 425, 455	6.295"	8.5"
Pontiac 326, 350, 389, 400, 421, 428, 455	6.295"	9.1"

**RACE ONLY HEI DISTRIBUTORS**

Race HEI units use all new components and feature an electronic module and coil combination that optimizes spark energy and peak current to the spark plug in the 6000 to 8500 RPM range.

Compared to our street/strip version, race units produce 42% more energy with 46% faster spark breakdown time allowing 48% more peak current to reach the spark plug. This abundant energy doubles the spark intensity during the critical one millisecond of burn time.

Great for both circle track and drag race applications where factory type HEI distributors are mandated.

**FEATURES**

- New lightweight A384 cast aluminum alloy housing.
- Aligned and honed high quality bronze sintered bushings for reduced friction and extended life.
- Centerless ground corrosion resistant shaft reduces friction and provides concentric operation.
- RACE ONLY 7.2 amp module and 50,000 volt coil.
- Distributor gear is ground to exact tolerances for tighter mesh with cam. (Bronze distributor gear available)
- High dielectric strength cap with solid brass terminals and low resistance center coil brush.
- Balanced rotor with nylon screws prevent arcing and reduce vibration at high RPMs.
- Specially designed vacuum lockout prevents changes to rotor phasing to maximize combustion burn time at high RPMs.
- Tig welded rotor and advance plates prevent high RPM distortion while improving reliability.
- Precision machined chromoly advance weights and center plate eliminate erratic timing.
- Additional advance springs included for fine tuning the advance curve to your needs.
- Limited One Year Warranty.
- Not legal for sale or use on pollution controlled motor vehicles.



**FLAME-THROWER DISTRIBUTORS**



Description			
<b>CHEVROLET SB &amp; BB (STANDARD DECK HEIGHT)</b>			
Cast finish	D1070	D1071	-----
<b>FORD 221, 260, 289 &amp; 302 (EXCLUDES '84 AND LATER 5.0L)</b>			
Machine polished	D1370	-----	D1372
<b>OLDSMOBILE 260, 307, 330, 350, 400, 403 &amp; 455</b>			
Cast finish	D1170	D1171	-----
<b>PONTIAC 301, 326, 350, 389, 400, 421, 428 &amp; 455</b>			
Cast finish	D1270	-----	D1272
<b>SERVICE PARTS</b>			
Replacement cap	D4050	D4051	D4052
Replacement rotor		D4061	D4062

**BRONZE DISTRIBUTOR GEAR**

**NEW**

Made from superior quality bronze aluminum and precision CNC machined to provide smooth consistent operation while reducing wear to your camshaft.



**D6001**

### PERFORMANCE TUNE-UP KITS

Everything you need to “wake up” your stock Chevy, Olds, Pontiac, Cadillac or Buick distributor. Kits include street-strip 4-pin module and coil combination, premium rotor and cap, custom Flame-Thrower coil cover, adjustable vacuum advance canister, hi-performance advance kit, wire harness and capacitor, and complete installation hardware. “Race Only” tune-up kits bring HEI equipped circle track or drag race engines back to life. These kits include matching coil and module, wiring harness, vacuum lock out, advance weights, springs, bushings, cap, rotor, dust shield, and necessary hardware.



Description	Black	Red	Blue
Chevrolet and Cadillac V8 (red/yellow wire coil)	D8000	D8001	D8002
Buick, Oldsmobile, Pontiac and Corvette (red/white wire coil)	D8010	D8011	D8012
Race Only Tune-Up Kit	D8070*	D8071*	

### CAPS, ROTORS AND DUST COVERS

Made from hi-performance 60 KV rated alkyd molding compound for superior protection from “arc-thru” and cross-fire. Our cap and rotor kits include nylon rotor hold-down screws. Flame-Thrower dust covers provide a larger air gap around the coil which provides cooler operating temperatures.

Description	Black	Red	Blue
Distributor cap and rotor kits	D4000	D4001	D4002
Distributor cap	D4050	D4051	D4052
Distributor rotor		D4061	D4062
Dust cover with Flame-Thrower script	D9000		
Distributor cap late model EST	D4150	D4151	
Distributor rotor late model EST	D4260		



D4001



D9000



D4151

### WIRING HARNESS AND CAPACITOR

Premium quality wire harness and capacitor insure good connection and “static free” operation.

### MECHANICAL ADVANCE CURVE KIT

Precision machined chromoly weights and center plate eliminate erratic timing. Three sets of springs, guide bushings and complete installation instructions make recurving your distributor easy.



D9007

### VACUUM ADVANCE & LOCKOUT

These vacuum canisters help optimize ignition advance for maximum part throttle performance and cruise speed efficiency. Our vacuum lockout plates allow for precise pickup coil position and accurate rotor phasing.



D9001

### BRONZE DISTRIBUTOR GEAR

Made from superior quality bronze aluminum and precision CNC machined to provide smooth consistent operation while reducing wear to your camshaft.



D9006

Description	Part #
Wiring harness and capacitor	D9007
Adjustable vacuum advance canister	D9006
Clockwise vacuum lockout	D9010*
Counter clockwise vacuum lockout	D9011*
Mechanical advance curve Kit	D9001
Bronze gear Chevrolet SB and BB engines 0.491 shaft	D6001



D9010



D6001

**NEW**

\* Not legal for sale or use on pollution controlled motor vehicles



## PERFORMANCE IGNITION MODULES

Our performance ignition modules are direct replacements for popular GM and Ford electronic distributors. These modules provide enhanced high RPM performance and when used with their corresponding Flame-Thrower coil, increase spark plug voltage by more than 40%.

### FEATURES

- Thick film technology on alumina ceramic substrates removes heat for greater accuracy and improved reliability.
- Laser trimming gives precise peak current control for increased energy output.
- Each module is tested twice with automated equipment to insure trouble free operation.
- Legal in all 50 states and Canada. (C.A.R.B. E.O. #D-57-22)\*
- Limited One Year Warranty.

\* Race Only modules are not legal for sale or use on pollution controlled motor vehicles



Years	Original Module Part Numbers	Amps	Coil	Module
<b>GM 4-PIN MODULE</b>				
1974-88	AC-Delco (D1906) American Motors (8131941) Delco (1875990 & 1894322)	6.9	D3000 - D3001	D2000
Universal	Developed specifically for racing applications. Use with matching "RACE ONLY" coil for maximum output.	7.2	D3070*	D2070*
<b>GM 7-PIN MODULE</b>				
1980-91	AC-Delco (D1948, D1952, D1956, D1963A, D1968, D1973) Delco (1988500, 1977907, 1978617, 1987714, 1976908)	4.0	D3000 - D3001	D2001
<b>GM 8-PIN MODULE</b>				
1985-94	AC-Delco (D1978, D1979, D1990, D1993) Delco (1987465, 1987466, 10469931, 10496048, 10496269, 10496541, 10496784, 6139369, 16139389, 16140039)	4.0	D3002	D2002
<b>FORD TFI MODULE</b>				
1983-93	Ford (E3EF-12A297-A1A, E3EF-12A297-A2A, E6EF-12A297-AA, E43Z-12A297-A E8FZ-12A297A) Motorcraft (DY425)	4.0	D3003	D2010



D2000



D2001



D2002



D2010

### RACE ONLY 4-PIN HEI MODULE

"Race Only" 4-pin HEI modules are built with heavy duty components and engineered to create 42% more energy than street strip versions when combined with "Race Only" coils.



D2070\*

### Flame-Thrower® 40,000 VOLT CANISTER COILS

While it's the perfect coil to go with the PerTronix Ignitor breakerless ignition, our 40,000 volt Flame-Thrower canister coil can benefit virtually any distributor type inductive system. Its higher voltage allows larger spark plug gaps for added power, smoother response and better fuel economy. These coils are internally resisted so installation and wiring is drastically simplified. Our oil filled coils offer great heat control for street driven vehicles, while our epoxy filled coils provide superior winding support for high vibration environments in off-road vehicles and boats.

#### FEATURES

- 40,000 volts.
- Available chrome plated or black for that "stock look".
- For use with inductive ignition systems.
- 1.5 or 3.0 Ohm primary resistance values available.
- Legal in all 50 states and Canada. (C.A.R.B. E.O. #D-57-21)
- Limited 90 Day Warranty.

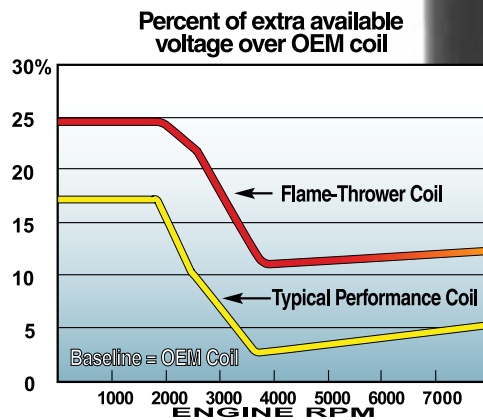

Eight cylinder engine with PerTronix Ignitor installed.

### Flame-Thrower® II 45,000 VOLT CANISTER COILS

Flame-Thrower II coils feature a very low resistance which make them the ideal coil for Ignitor II ignition systems as well as many other high performance ignitions. Low resistance and improved turns ratio help to produce up to 45,000 volts. This higher voltage enables you to run larger spark plug gaps for added power and better fuel economy. These coils are also compatible with most capacitive discharge boxes including our own Second Strike.

#### FEATURES

- 45,000 volts.
- Available chrome plated or black for that "stock look".
- For use with inductive or CD ignition systems.
- Low 0.6 Ohm primary resistance.
- Legal in all 50 states and Canada. (C.A.R.B. E.O. #D-57-21)
- Limited 90 Day Warranty.

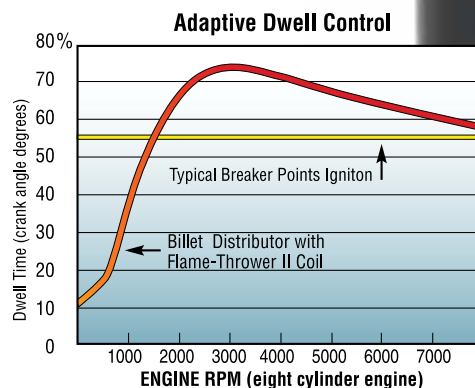

FLAME-THROWER COILS



# Flame-Thrower III 45,000 VOLT CANISTER COILS

Flame-Thrower III coils feature a ultra low resistance and are designed specifically for the new Ignitor III ignition system. Flame Thrower III coils have a high turns ratio and ultra low primary resistance enabling the ignition system to charge faster at high RPM's.

## FEATURES

- 45,000 volts.
- Ultra Low 0.32 primary resistance.
- Compatible with Ignitor II and III systems as well as most capacitive discharge systems.
- Charges to peak current typically 30-70% faster than other coils.
- Rapid charge time means maximum spark energy is sustained to higher engine RPM.
- Legal in all 50 states and Canada. (C.A.R.B. E.O. #D-57-21)
- Limited 90 Day Warranty.

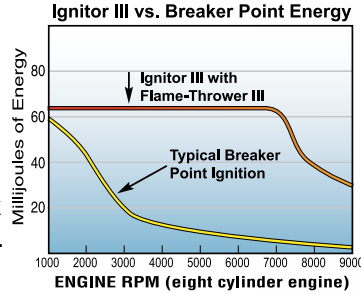

Ignition Type	System Voltage	Resistance	Application	28,000 Volts	40,000 Volts	45,000 Volts
<b>IGNITOR</b> or points	12V	3 Ω	4 & 6 cylinder engines	28010	40501, 40511 40611	
	12V	1.5 Ω	8 cylinder engine		40001, 40011 40111	
	6V	1.5 Ω	4 & 6 cylinder engines		40001, 40011 40111	
	6V	0.6 Ω	8 cylinder engines			45001, 45011 45111
<b>Ignitor II</b>	12V	0.32-0.6 Ω	4, 6 and 8 cylinder engines			45001, 45011 45111 44001, 44011
<b>Ignitor III</b>	12V	0.32 Ω	8 cylinder engines			44001, 44011

Note: Shaded area of application chart applies to positive ground as well as negative ground applications.

Part No.	Description	Finish	Turn Ratio	Primary Resistance	Secondary Resistance	Primary Inductance	Maximum Voltage	Height	Diameter
<b>FLAME-TROWER 40,000 VOLT COILS</b>									
40001	Flame-Thrower Oil Filled	Chrome	115:1	1.5 Ohms	10.6k Ohms	6.4mH	40,000	6.0"	2.15"
40011	Flame-Thrower Oil Filled	Black	115:1	1.5 Ohms	10.6k Ohms	6.4mH	40,000	6.0"	2.15"
40501	Flame-Thrower Oil Filled	Chrome	73:1	3.0 Ohms	8.5k Ohms	11.1mH	40,000	6.0"	2.15"
40511	Flame-Thrower Oil Filled	Black	73:1	3.0 Ohms	8.5k Ohms	11.1mH	40,000	6.0"	2.15"
40111	Flame-Thrower Epoxy Filled	Black	115:1	1.5 Ohms	10.6k Ohms	6.4mH	40,000	6.0"	2.15"
40611	Flame-Thrower Epoxy Filled	Black	73:1	3.0 Ohms	8.5k Ohms	11.1mH	40,000	6.0"	2.15"
<b>FLAME-TROWER II 45,000 VOLT COILS</b>									
45001	Flame-Thrower II Oil Filled	Chrome	108:1	0.6 Ohms	10.0k Ohms	7.2mH	45,000	6.0"	2.15"
45011	Flame-Thrower II Oil Filled	Black	108:1	0.6 Ohms	10.0k Ohms	7.2mH	45,000	6.0"	2.15"
45111	Flame-Thrower II Epoxy Filled	Black	108:1	0.6 Ohms	10.0k Ohms	7.2mH	45,000	6.0"	2.15"
<b>FLAME-TROWER III 45,000 VOLT HIGH CURRENT COILS</b>									
44001	Flame-Thrower III Oil Filled	Chrome	110:1	0.32 Ohms	7.3k Ohms	2.5mH	40,000	6.0"	2.15"
44011	Flame-Thrower III Oil Filled	Black	110:1	0.32 Ohms	7.3k Ohms	2.5mH	40,000	6.0"	2.15"
<b>SPECIALITY INDUSTRIAL COIL</b>									
28010	Oil Filled	Black	50:1					6.0"	2.15"
<b>UNIVERSAL COIL BRACKETS</b>									
10001	Coil bracket	Zinc							
10002	Coil bracket	Chrome							

# Flame-Thrower<sup>®</sup> HC

60,000 VOLT COIL

**NEW**

New HC (HIGH CURRENT) E-core coils were engineered specifically for our Ignitor III ignition modules. HC coils have a high turns ratio and ultra low primary resistance enabling the ignition system to charge faster at high RPM's. The coil is supported in a special heat sink made from aircraft 6063 T5 aluminum which efficiently transfers heat away from the windings.

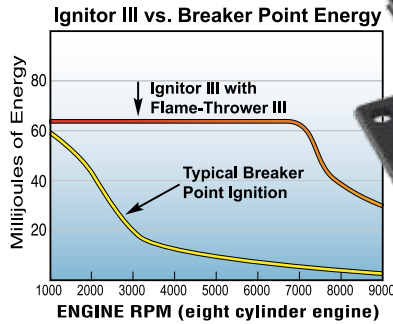

# Flame-Thrower<sup>®</sup> HV

60,000 VOLT COIL

Our HV (HIGH VOLTAGE) E-core design yields an incredible 60,000 volts and operates with no degradation throughout temperature ranges that surpass military specifications. The special heat sink design made from aircraft 6063 T5 aluminum efficiently transfers heat optimizing energy output for street/strip and off road applications. Flame-Thrower HV .45 ohm coils are also compatible with most capacitive discharge boxes including our own Second Strike.



### FEATURES

- 60,000 volts.
- Highly efficient E-core design.
- Vacuum potted coil body for longer life and increased reliability.
- 6063 T5 aluminum heat sink with black anodized corrosion resistant finish.
- Precision machined male high tension terminal and brass primary terminals.
- Legal in all 50 states and Canada. (C.A.R.B. E.O. #D-57-21)
- Limited 90 Day Warranty.

### APPLICATION CHART

Ignition Type	Application	Part No.
<b>IGNITOR<sup>®</sup> or points</b>	4 & 6 cylinder engines	60130
	8 cylinder engine	60115
<b>Ignitor<sup>®</sup> II</b>	4, 6 and 8 cylinder engines	60104 60103
	<b>Ignitor<sup>®</sup> III</b>	8 cylinder engines

Note: Shaded area of application chart applies to positive ground as well as negative ground applications.

Part No.	Description	Finish	Turn Ratio	Primary Resistance	Secondary Resistance	Primary Inductance	Maximum Voltage	Length	Width	Height
<b>60,000 VOLT HV COILS</b>										
60104	HV Epoxy Filled E-core design	Black	93:1	0.45 Ohms	7.3k Ohms	3.8mH	60,000	4.6"	4.65"	3.15"
60115	HV Epoxy Filled E-core design	Black	83:1	1.5 Ohms	14.4k Ohms	6.4mH	60,000	4.6"	4.65"	3.15"
60130	HV Epoxy Filled E-core design	Black	85:1	3.5 Ohms	22.8k Ohms	9.0mH	60,000	4.6"	4.65"	3.15"
<b>60,000 VOLT HC COILS</b>										
60103	HC Epoxy Filled E-core design	Black	110:1	0.32 Ohms	6.0k Ohms	2.8mH	60,000	4.6"	4.65"	3.15"

FLAME-THROWER COILS

### 50,000 VOLT E-CORE COILS

Flame-Thrower E-Core coils feature optimized winding design to maximize spark gap current and available voltage. When teamed with Flame-Thrower ignition modules they produce 100% more energy across the spark plug gap (during a one millisecond burn time) compared to the OEM coil. Select one of our matching Flame-Thrower ignition modules on page 47 for a performance proven combo.

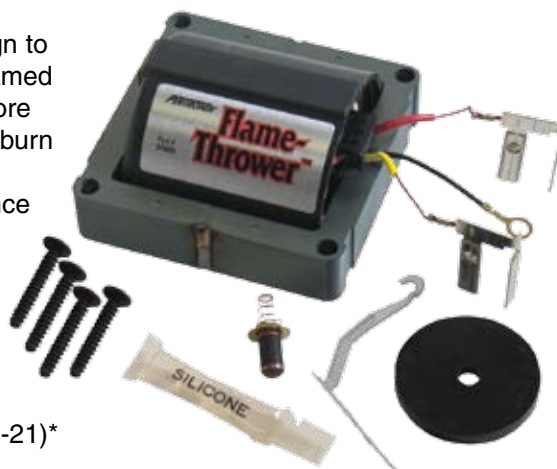

#### FEATURES

- 50,000 volts.
- Ultra low primary resistance values.
- Legal in all 50 states and Canada. (C.A.R.B. E.O. #D-57-21)\*
- Limited 90 Day Warranty.

\* "RACE ONLY" coils are not legal for sale or use on pollution controlled motor vehicles

### GM HEI COILS



D3000

Replaces internal GM coils with black, yellow and red wires. Includes all necessary hardware.



D3001

Replaces internal GM coils with black, white and red wires. Includes all necessary hardware.



D3070\*

"Race Only" coils when paired with race modules produce 42% more energy than our street/strip version with 46% faster spark breakdown time allowing 48% more peak current to reach the spark plug between 6000 and 8500 RPM. Includes all necessary hardware.

\* Not legal for sale or use on pollution controlled motor vehicles

**FORD TFI E-CORE COIL**

Flame-Thrower 50,000 volt TFI style coils breath new life into your 1982-96 Ford Lincoln and Mercury ignition system. For maximum performance use our Flame-Thrower ignition modules found on page 47.

**D3003**

**D3002**

Replaces remote GM coils found on 1985-95 Buick, Cadillac, Chevrolet, Oldsmobile and Pontiac vehicles.

Part No.	Description	Finish	Turn Ratio	Primary Resistance	Secondary Resistance	Primary Inductance	Maximum Voltage	Matching Module
<b>FLAME-THROWER 50,000 VOLT E-CORE COILS</b>								
D3000	GM internal E-core coil with yellow wire	Black	78:1	0.5 Ohms	8.3k Ohms	4.4mH	50,000	D2000/D2001
D3001	GM internal E-core coil with white wire	Black	78:1	0.5 Ohms	8.3k Ohms	4.4mH	50,000	D2000/D2001
D3002	GM Remote E-core coil	Black	111:1	0.32 Ohms	6.8k Ohms	2.5mH	50,000	D2002
D3003	Ford TFI E-core coil	Black	93:1	0.32 Ohms	6.0k Ohms	2.8mH	50,000	D2010
D3070*	GM internal Racing E-core coil	Black	94:1	0.35 Ohms	8.4k Ohms	2.8mH	50,000	D2070

\* Not legal for sale or use on pollution controlled motor vehicles

## THE ULTIMATE IGNITION SUPPLEMENT

Second Strike is the only ignition system to provide a powerful second spark throughout the entire RPM range. Other multiple spark discharge systems typically revert to one spark at about 3000 RPM. The "Second Strike" is a microcontroller based ignition supplement that works with most inductive type systems (points, GM HEI, Chrysler electronic ignition, Ford TFI and Duraspark, Ignitor and Ignitor II). Following the primary spark, the Second Strike delivers a powerful capacitive discharge second spark resulting in more complete combustion. At very high RPM's the increased burn time can reduce misfires resulting in more peak horsepower and torque.

Second Strike's unique crank angle offset (CAO) feature gives you tunability that no other box has. Simply turn the dial and change the time, in crank angle degrees, that the second spark occurs. A wide range of adjustment gives you the flexibility to find which CAO works best for your engine.

The integrated digital rev limiter features easy to use rotary switches that adjust the RPM limit to an ultra fine resolution of 100 RPMs, eliminating the need for old resistor style pills or chips. Proprietary algorithms provide superior control of rev limit and a rapid response time to over rev events, preventing engine failure.

Easy installation with a simple five wire hookup and detailed instructions. No special distributor or ignition coil are required.



**TYPICAL MULTI-SPARK CD SYSTEM ABOVE 3000 RPM**

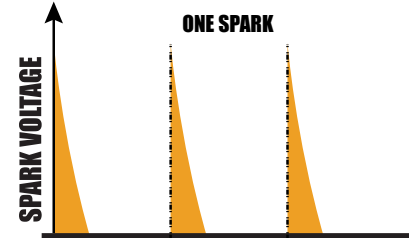

**SECOND STRIKE ABOVE 3000 RPM**

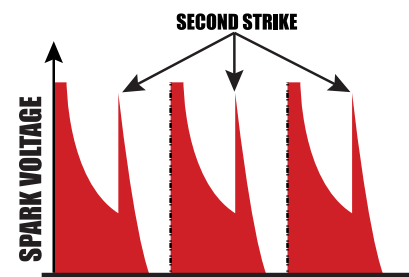

### FEATURES

- Only system to provide a second spark throughout the RPM range.
- Powerful CD second spark resulting in more complete combustion.
- Increased burn time increases horsepower and torque at high RPMs.
- Unique (CAO) feature adjusts the timing of the second spark.
- Built-in digital rev limiter with high resolution.
- Digital rotary switches permit easy adjustment.
- Adaptive voltage feature prevents overdriving the ignition coil.
- Voltage protection prevents damage from reversed polarity.
- Tachometer output with TTL interface and near 50% duty cycle make our limiters compatible with most modern tachometers.
- Legal in all 50 states and Canada. (C.A.R.B. E.O. #D-57-22)
- Limited One Year Warranty.

Description	Part No.
Second Strike	500

#### Application Notes:

- For 4, 6 and 8 cylinder even fire engines with single coil inductive ignition system
- 12 Volt negative ground
- Not for use on computer controlled vehicles

### SPECIFICATIONS

Spark Energy:	245MJ
Primary Voltage:	200-700 Volts
Spark Timing:	Adjustable 2° -18°
Voltage Required:	11-18 VDC
Current Draw:	3.5 Amps @5000 RPM
Size:	6"L X 4"W X 3"H
Weight:	2.3 Lbs.

## FOOL PROOF CONTROL...

Flame-Thrower digital rev limiters work with any 4, 6 or 8 cylinder engine using points, OEM electronic (GM HEI, Ford, Chrysler) or aftermarket inductive type ignition systems including our very popular Ignitor and Ignitor II points replacement systems.

This digital microcontroller based unit provides a much greater accuracy (+/-0.01%) over analog systems. There is no need for old resistor style pills or chips, our easy to use rotary switches adjust the RPM limit to an ultra fine resolution of 100 RPMs. Our proprietary algorithms provides superior control of rev limits and a rapid response time to over rev limit events, preventing engine failure. Rev limiters come with multiple analog filters and one digital filter to prevent coil noise interference from affecting the established rev limit.

Installation is a snap with a four wire hookup and easy to understand instructions. The rev limiter's small size permits installation in even the most crowded engine compartment.



## FEATURES

- Digital microcontroller based unit provides greater accuracy (+/-0.01%) over analog systems.
- Easy to use rotary switches permit settings with a resolution of 100 RPMs.
- Tachometer output with TTL interface and near 50% duty cycle make our limiters compatible with most modern tachometers.
- Reverse voltage protection.
- Conformal coated surface mount PCB for reliability .
- Easy four wire hookup.
- Compact size: 3"L X 2.5"W X 1.4"H.
- Lightweight: 0.75 LBS.
- Legal in all 50 states and Canada. (C.A.R.B. E.O. #D-57-22)
- Limited One Year Warranty.



Description	Part No.
Digital Rev Limiter	600

### Application Notes:

- For 4, 6 and 8 cylinder even fire engines with single coil inductive ignition system
- 12 Volt negative ground
- Not for use with (CD) Capacitive Discharge systems

### 8MM CUSTOM FIT MAGX2 SPARK PLUG WIRES

8mm Custom fit MAGx2 wires are available for many popular applications equipped with Flame-Thrower or original GM HEI distributors. Our custom wire sets have factory terminated ends for a superior connection and perfect fit, without cutting, crimping and splicing.



#### FEATURES

- Two current paths for reliability and redundancy.
  - Primary path: Spiral wound stainless steel alloy.
  - Secondary path: Carbon impregnated fiberglass center core.
- Low 500 ohm per foot resistance.
- 8mm Silicone jacket to resist high temperatures, moisture, oil and chemicals.
- EPDM (Ethylene Propylene Diene Methylene) inner insulation for superior heat resistance and prevention of arcing and voltage leaks.
- Fiberglass reinforcing braid for added strength and flexibility.
- Lifetime Warranty.

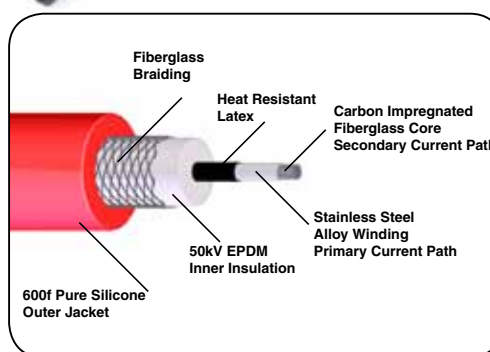

Year	Model	Cyl	Plug Boot	Dist Boot	Black Part No.	Blue Part No.	Red Part No.
<b>BUICK</b>							
1974-75	Apollo 350	8	90°	90°	808201	808302	808403
1974-77	Century, Electra, LeSabre, Regal, Riviera 350	8	90°	90°	808201	808302	808403
1975	Apollo with Oldsmobile 260 engine	8	90°	90°	808204	808305	808406
1975	LeSabre with Pontiac 400 engine	8	90°	90°	808201	808302	808403
1975-76	Skylark 350	8	90°	90°	808201	808302	808403
1975-76	Skylark with Oldsmobile 260 engine	8	90°	90°	808204	808305	808406
1975-77	Skylark with Oldsmobile 350 engine	8	90°	90°	808204	808305	808406
1977	Century, Regal with Chevrolet 305-350 engine	8	90°	90°	808210	808311	808412
1977	Century, Regal with Oldsmobile 350-403 engine	8	90°	90°	808204	808305	808406
1977	Skylark with Pontiac 301 engine	8	90°	90°	808201	808302	808403
1977-78	Riviera with Oldsmobile 403 engine	8	90°	90°	808204	808205	808406
1977-78	Skylark with Chevrolet 305-350 engine	8	90°	90°	808210	808311	808412
1977-79	Electra, LeSabre with Oldsmobile 403 engine	8	90°	90°	808204	808305	808406
1977-80	Electra, LeSabre, Riviera with Oldsmobile 5.7L 350 engine	8	90°	90°	808204	808305	808406
1977-81	LeSabre with Pontiac 4.9L 301 engine	8	90°	90°	808201	808302	808403
1978	Century with Chevrolet 305-350 engine (Uses two straight boots)	8	90°	90°	808207	808308	808409
1978	LeSabre with Chevrolet 305-350 engine	8	90°	90°	808210	808311	808412
1978	Regal with Chevrolet 305-350 engine (Uses two straight boots)	8	90°	90°	808207	808308	808409
1978-80	Electra, LeSabre, Riviera 5.7L 350	8	90°	90°	808201	808302	808403
1979	Skylark with Chevrolet 305-350 engine	8	90°	90°	808210	808311	808412
1979-80	Century, Regal with Pontiac 4.9L 301 engine	8	90°	90°	808201	808302	808403
1980-81	Century, Regal with Pontiac 4.3L 265 engine	8	90°	90°	808201	808302	808403
1980-85	Riviera 5.0L 307	8	90°	90°	808204	808305	808406
1980-85	Electra, LeSabre 5.7L 350 (Canada only)	8	90°	90°	808201	808302	808403
1981-83	Electra 5.0L 307	8	90°	90°	808204	808305	808406
1981-84	LeSabre 5.0L 307	8	90°	90°	808204	808305	808406
1981-90	Estate Wagon 5.0L 307	8	90°	90°	808204	808305	808406
1986-87	Regal 5.0L 307	8	90°	90°	808204	808305	808406
1987	Regal 5.0L 305 (Canada only) (Uses two straight boots)	8	90°	90°	808207	808308	808409
<b>CADILLAC</b>							
1986-90	Fleetwood Brougham 5.0L 307	8	90°	90°	808204	808305	808406
1976-80	Eldorado, Seville w/fuel inj 5.7L 350	8	90°	90°	808204	808305	808406



New applications appear in red

Year	Model	Cyl	Plug Boot	Dist Boot	Black Part No.	Blue Part No.	Red Part No.
<b>CHEVROLET</b>							
1974-82	Corvette 5.7L 350 (Longer wires for under exhaust design)	8	90°	90°	808213	808314	808419
1974-79	Camaro, Caprice, Impala, Nova 350	8	90°	90°	808210	808311	808412
1974-77	Malibu, Monte Carlo 350	8	90°	90°	808210	808311	808412
1974-76	Caprice, Chevelle, Impala 350	8	90°	90°	808210	808311	808412
1974-76	Caprice, Impala 454	8	Straight	90°	808216	808317	808418
1974-75	Belair 350	8	90°	90°	808210	808311	808412
1974-75	Belair, Chevelle, Malibu, Monte Carlo 454	8	Straight	90°	808216	808317	808418
1974	Corvette 454Z	8	Straight	90°	808216	808317	808418
1975	Nova 262	8	90°	90°	808210	808311	808412
1976-79	Camaro, Nova 305	8	90°	90°	808210	808311	808412
1976-77	Malibu, Monte Carlo, Monza 305	8	90°	90°	808210	808311	808412
1976	Chevelle 305	8	90°	90°	808210	808311	808412
1977-79	Caprice, Impala 305	8	90°	90°	808210	808311	808412
1978	Malibu, Monte Carlo 305, 350	8	90°	90°	808207	808308	808409
1980-82	Caprice, Impala 5.7L 350 (Uses two straight boots)	8	90°	90°	808207	808308	808409
1980	Camaro 4.4L 267, 5.0L 305, 5.7L 350 (Excluding California)	8	90°	90°	808210	808311	808412
1981-86	Caprice, Impala, Monte Carlo 5.0L 305 (Uses two straight boots)	8	90°	90°	808207	808308	808409
1981-83	Malibu 5.0L 305 (Uses two straight boots)	8	90°	90°	808207	808308	808409
1981-82	Caprice, Impala, Malibu, Monte Carlo 4.4L 267 (Uses two straight boots)	8	90°	90°	808207	808308	808409
1983-86	Camaro 5.0L 305 (Uses two straight boots)	8	90°	90°	808207	808308	808409
1983-86	Caprice, Impala 5.7L 350 (Uses two straight boots)	8	90°	90°	808207	808308	808409
1983	Camaro 5.0L 305 with cross-fire inj, 5.0L 305 (Uses two straight boots)	8	90°	90°	808207	808308	808409
1984-86	Camaro with high output, 4BBL 5.0L 305 (Uses two straight boots)	8	90°	90°	808207	808308	808409
1984-86	Monte Carlo SS with high output, 4BBL 5.0L 305 (Uses two straight boots)	8	90°	90°	808207	808308	808409
1986-87	Impala 5.0L 307	8	90°	90°	808204	808305	808406
1987-90	Caprice 5.0L 307	8	90°	90°	808204	808305	808406
<b>CHEVROLET / GMC TRUCK</b>							
1974-77	El Camino, Cabellero 305, 350	8	90°	90°	808210	808311	808412
1975-82	Motor Home, P Series Van 6.0L 366, 7.0L 427	8	Straight	90°	808216	808317	808418
1975-80	Blazer, Jimmy, PU, Van, Suburban 305, 350, 400	8	90°	90°	808210	808311	808412
1975-79	PU, Motor Home Chassis, Van, Suburban 7.4L 454	8	Straight	90°	808216	808317	808418
1978	El Camino, Cabellero 305, 350 (Uses two straight boots)	8	90°	90°	808207	808308	808409
1980-85	Suburban, 2500HD, 3500 PU 7.4L 454	8	Straight	90°	808216	808317	808418
1980-85	Motor Home Chassis, P Series Van 7.4L 454	8	Straight	90°	808216	808317	808418
1981-86	El Camino, Cabellero 5.0L 305 (Uses two straight boots)	8	90°	90°	808207	808308	808409
1981-86	G, P Series Vans, Motor Home Chassis 5.0L 305, 5.7L 350	8	90°	90°	808210	808311	808412
1981-86	Suburban 5.0L 305, 5.7L 350	8	90°	90°	808210	808311	808412
1981-82	El Camino, Cabellero 4.4L 267 (Uses two straight boots)	8	90°	90°	808207	808308	808409
1981	El Camino, Cabellero, with Pontiac 4.3L 265 engine	8	90°	90°	808201	808302	808403
1983-86	Blazer, Jimmy, PU, Suburban 5.0L 305, 5.7L 350 (Uses two straight boots)	8	90°	90°	808207	808308	808409
1987-88	G30, 35, P Series Van with 4BBL 5.7L 350	8	90°	90°	808210	808311	808412
1987-88	Motor Home Chassis with 4BBL 5.7L 350	8	90°	90°	808210	808311	808412
1987-88	Suburban with 4BBL 5.7L 350	8	90°	90°	808210	808311	808412
1988-89	2500HD, 3500 PU with 4BBL 5.7L 350	8	90°	90°	808210	808311	808412
<b>FORD</b>							
1966-72	Bronco All 8 Cyl.	8	Straight	90°	808220	808321	
1962-70	Fairlane All 8 Cyl.	8	Straight	90°	808220	808321	
1963-70	Falcon All 8 Cyl.	8	Straight	90°	808220	808321	
1964-73	F-Series All 8 Cyl.	8	Straight	90°	808220	808321	
1961-74	Full Size - Custom, Galaxie, LTD, Crown Victoria All 8 Cyl	8	Straight	90°	808220	808321	
1958-60	All 8 Cyl. exc. 292	8	Straight	90°	808220	808321	
1968-76	LTD II, Torino, Ranchero All 8 Cyl	8	Straight	90°	808220	808321	
1965-73	Mustang All 8 Cyl.	8	Straight	90°	808220	808321	
1958-72	Thunderbird All 8 Cyl.	8	Straight	90°	808220	808321	



808311



808220

Year	Model	Cyl	Plug Boot	Dist Boot	Black Part No.	Blue Part No.	Red Part No.
<b>LINCOLN</b>							
1958-72	Continental All 8 Cyl.	8	Straight	90°	808220	808321	
<b>MERCURY</b>							
1966-71	Comet, Meteor All 8 Cyl.	8	Straight	90°	808220	808321	
1968-74	Cougar All 8 Cyl.	8	Straight	90°	808220	808321	
1958-74	Full Size - Grand Marquis, Monterey All 8 Cyl exc. 292 cid	8	Straight	90°	808220	808321	
1968-74	Montego All 8 Cyl.	8	Straight	90°	808220	808321	
<b>OLDSMOBILE</b>							
1974-77	Omega 260, 350	8	90°	90°	808204	808305	808406
1974-76	98, Cutlass, Delta 88, Toronado 350, 455	8	90°	90°	808204	808305	808406
1975-82	Cutlass Supreme, Delta 88 4.3L 260	8	90°	90°	808204	808305	808406
1976-80	98, Cutlass, Delta 88 with Chevrolet 5.7L 350 engine	8	90°	90°	808204	808305	808406
1977-79	98, Cutlass, Delta 88 403	8	90°	90°	808204	808305	808406
1977-79	Omega with Chevrolet 305, 350 engine	8	90°	90°	808210	808311	808412
1977-78	Toronado 403	8	90°	90°	808204	808305	808406
1977	Delta 88, Starfire with Chevrolet 305, 350 engine	8	90°	90°	808210	808311	808412
1978	Cutlass with Chevrolet 305, 350 engine (Uses two straight boots)	8	90°	90°	808207	808308	808409
1979-80	Toronado with Chevrolet 5.7L 350 engine	8	90°	90°	808204	808305	808406
1979	Delta 88 with Pontiac 301 engine	8	90°	90°	808201	808302	808403
1980-85	Toronado 5.0L 307	8	90°	90°	808204	808305	808406
1980-84	98, Delta 88 5.0L 307	8	90°	90°	808204	808305	808406
1981-88	Cutlass Supreme 5.0L 307	8	90°	90°	808204	808305	808406
1985-90	Custom Cruiser 5.0L 307	8	90°	90°	808204	808305	808406
<b>PONTIAC</b>							
1973-75	Grand Am, Grandville 350, 400, 455	8	90°	90°	808201	808302	808403
1973-76	Bonneville, Catalina, Grand Prix, LeMans 455, 350	8	90°	90°	808201	808302	808403
1973-77	Firebird, Grand Prix	8	90°	90°	808201	808302	808403
1973-78	Bonneville, Catalina 400	8	90°	90°	808201	808302	808403
1973-79	Firebird 400	8	90°	90°	808201	808302	808403
1975-76	Ventura with Oldsmobile 260 engine	8	90°	90°	808204	808305	808406
1976	LeMans with Oldsmobile 260 engine	8	90°	90°	808204	808305	808406
1976-77	Bonneville, Catalina, Grand Prix 350	8	90°	90°	808201	808302	808403
1977	Grand Prix, LeMans, Phoenix, Ventura with Oldsmobile 350, 403 engine	8	90°	90°	808204	808305	808406
1977	Ventura, with Chevrolet 305, 350 engine	8	90°	90°	808210	808311	808412
1977	Ventura 301	8	90°	90°	808201	808302	808403
1977-78	LeMans with Chevrolet 305 engine (Uses two straight boots)	8	90°	90°	808207	808308	808409
1977-79	Bonneville, Catalina, Firebird with Oldsmobile 403 engine	8	90°	90°	808204	808305	808406
1977-79	Firebird 301	8	90°	90°	808201	808302	808403
1977-79	Firebird, Phoenix with Chevrolet 305, 350 engine	8	90°	90°	808210	808311	808412
1977-80	Bonneville, Catalina, Grand Prix, LeMans 4.9L 301	8	90°	90°	808201	808302	808403
1977-80	Bonneville, Catalina with Oldsmobile 5.7L 350 engine	8	90°	90°	808204	808305	808406
1978	Grand Am, LeMans with Chevrolet 305, 350 engine (Uses two straight boots)	8	90°	90°	808207	808308	808409
1978	Grand Prix with Chevrolet 305, 350 engine	8	90°	90°	808210	808311	808412
1978-79	Firebird with Chevrolet 350 engine	8	90°	90°	808210	808311	808412
1978-80	Bonneville, Catalina, with Buick 5.7L 350 engine	8	90°	90°	808201	808302	808403
1978-80	Grand Am 4.9L 301	8	90°	90°	808201	808302	808403
1980	Firebird 5.0L 305	8	90°	90°	808210	808311	808412
1980-81	Bonneville, Catalina, Grand Prix, LeMans 4.4L 265	8	90°	90°	808201	808302	808403
1980-81	Firebird 4.9L 301	8	90°	90°	808201	808302	808403
1981	Bonneville, Catalina 5.0L 307	8	90°	90°	808204	808305	808406
1981	Catalina, LeMans 4.4L 267 (Uses two straight boots)	8	90°	90°	808207	808308	808409
1981	Firebird 4.4L 265	8	90°	90°	808201	808302	808403
1981-82	Bonneville, Grand Prix 4.4L 267 (Uses two straight boots)	8	90°	90°	808207	808308	808409
1982-86	Firebird 5.0L 305 (Uses two straight boots)	8	90°	90°	808207	808308	808409
1983	Firebird 5.0L 305 with cross-fire inj (Uses two straight boots)	8	90°	90°	808207	808308	808409
1983-86	Bonneville, Grand Prix, Parisienne, Safari Wagon 5.0L (Uses two straight boots)	8	90°	90°	808207	808308	808409
1984-86	Firebird with 4BBL 5.0L 305 (Uses two straight boots)	8	90°	90°	808207	808308	808409
1986	Parisienne 5.0L 307	8	90°	90°	808204	808305	808406
1986-89	Safari Wagon 5.0L 307	8	90°	90°	808204	808305	808406

### 8MM MAGX2 SPARK PLUG WIRES FOR SPECIALITY APPLICATIONS

Aftermarket distributors often require different spark plug wires. If you don't have the tools or time to make your own wire set, we have the solution. Our custom tailored sets match most applications that use our line of Flame-Thrower performance distributors



Year	Model	Cyl	Plug Boot	Dist Boot	Black Part No.	Blue Part No.	Red Part No.	Yellow Part No.
<b>AUSTIN</b>								
1973-76	Marina All 4 Cyl.	4	90°	Straight	804206	804309	804412	-----
<b>MG</b>								
1967-80	MGB All 4 Cyl.	4	90°	Straight	804206	804309	804412	
1975-80	Midget 1500 cc	4	Straight	90°	804208	804311	804414	
<b>TRIUMPH</b>								
1952-67	TR2, TR3, TR4 All 4 Cyl.	4	Straight	90°	804207	804310	804413	
1962-81	Spitfire All 4 Cyl.	4	Straight	90°	804208	804311	804414	
1958-68	Herald 1200cc, 1300cc	4	Straight	90°	804208	804311	804414	
<b>VOLKSWAGEN</b>								
1961-79	All 4 cylinder type I engines with male terminal caps	4	Straight	90°	804202	804303	804404	804505
<b>CHEVROLET MARINE ENGINES</b>								
ALL	SB & BB Marine engines	8	Straight	90°	-----	-----	808450	-----

### 8MM MAGX2 UNIVERSAL SPARK PLUG WIRES

Universal 8mm spark plug wire kits allow you to build spark plug wires to match your unique engine and wire loom configuration. Universal kits are available with 90°, 45° or straight spark plug boot ends. Each kit includes terminals to fit both male and female terminal distributor caps.



Description	Plug Boot	Dist Boot	Black Part No.	Blue Part No.	Red Part No.
4 cylinder engines	Straight	90°	804280	804380	804480
4 cylinder engines with VW style spark plug boots	Straight	90°	8042VW	8043VW	8044VW
8 cylinder engines	45°	90°	808215	808315	808415
8 cylinder engines	Straight	90°	808280	808380	808480
8 cylinder engines	90°	90°	808290	808390	808490

### 8MM MAGX2 SPARK PLUG WIRE SPOOL

Now our 8MM wire featuring the "PerTronix Flame-Thrower MAGx2" Script is available by the spool. Each spool has 100 feet of wire, enough for four to five V8 engines.



Description	Part No.
100' Spool 8mm MAGx2 Spark Plug Wire Black	80S210

**NEW**

80S210

FLAME-THROWER SPARK PLUG WIRES

### 7MM "STOCK-LOOK" SPARK PLUG WIRES

Now you can get a "stock-look" spark plug wire, that performs! We've designed our 7mm wires with the same core we use in our 8mm wire. The only difference is the 7mm flat black silicone jacket that hides its performance potential from the naked eye. Get the best of both worlds with "state-of-the-art performance and a stock look." These wires will fit most original wire looms. Select a custom tailored set for a great out of the box fit or a universal kit to match your unique engine and wire loom configuration.



#### FEATURES

- Two current paths for reliability and redundancy.
  - Primary path: Spiral wound stainless steel alloy.
  - Secondary path: Carbon impregnated fiberglass center core.
- Low 500 ohm per foot resistance.
- 7mm Silicone jacket to resist high temperatures, moisture, oil and chemicals.
- EPDM (Ethylene Propylene Diene Methylene) inner insulation for superior heat resistance and prevention of arcing and voltage leaks.
- Fiberglass reinforcing braid for added strength and flexibility.
- Lifetime Warranty.

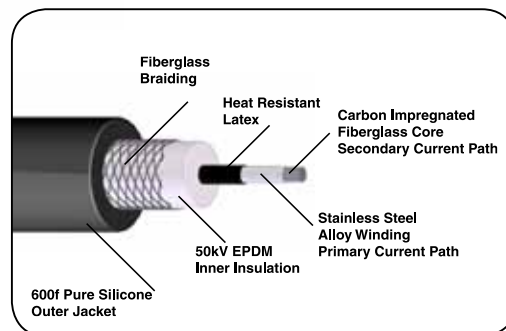

Year	Make / Model / Engine	Plug Boot	Dist Boot	Part No.
<b>AMERICAN MOTORS</b>				
1967-84	All 8 cylinder engines	Straight	Straight	708102
1960-66	All 8 cylinder engines	Straight	90°	708104
<b>BUICK</b>				
<b>Centurion, Electra, LeSabre, Riviera, Wildcat, Park Avenue</b>				
1970-74	All 8 cylinder engines without HEI distributor	Straight	Straight	708102
1967-69	350, 400, 430, 455 engines	Straight	Straight	708102
1967	340 engines	Straight	90°	708105
1960-66	All 8 cylinder engines	Straight	90°	708105
<b>Apollo, Century, Regal, Skyhawk, Skylark, Special, Super</b>				
1968-74	All 6 cylinder engines	Straight	90°	706101
1968-74	All 8 cylinder engines	Straight	Straight	708102
1967	400 engines	Straight	Straight	708102
1953-67	All 8 cylinder engines (excluding 1967 400 engines)	90°	Straight	708103
<b>CADILLAC</b>				
1963-74	All 8 cylinder engines without HEI distributor	Straight	Straight	708102
1959-62	All 8 cylinder engines	90°	Straight	708103
1954-58	All 8 cylinder engines	Straight	Straight	708102
<b>CHEVROLET</b>				
<b>BelAir, Biscayne, Caprice, Impala</b>				
1963-73	All 6 cylinder engines	Straight	90°	706101
1971-74	307, 350, 400 engines without HEI distributor	90°	Straight	708103
1965-74	396, 402, 427, 454 engines without HEI distributor	Straight	Straight	708102
1958-65	348, 409 engines	Straight	90°	708105
1955-70	283, 307, 327, 350, 400 engines (wires route under exhaust manifold)	90°	Straight	708101
<b>Camaro, Z-28, IROC-Z</b>				
1967-74	All 6 cylinder engines	Straight	90°	706101
1967-74	283, 302, 307, 327, 350 engines without HEI distributor	90°	Straight	708103
1967-72	396, 402, 427, 454 engines	Straight	Straight	708102

Year	Make / Model / Engine	Plug Boot	Dist Boot	Part No.
<b>CHEVROLET (CONTINUED)</b>				
<b>Celebrity, Citation, Chevy II, Nova</b>				
1962-74	All 6 cylinder engines	Straight	90°	706101
1968-74	307, 327, 350 engines without HEI distributor	90°	Straight	708103
1968-70	396, 402 engines	Straight	Straight	708102
<b>Chevelle, El Camino, Monte Carlo</b>				
1964-74	All 6 cylinder engines	Straight	90°	706101
1964-74	283, 307, 327, 350, 400 engines without HEI distributor	90°	Straight	708103
1965-74	396, 402, 427, 454 engines	Straight	Straight	708102
<b>Corvette</b>				
1965-74	396, 427, 454 engines	Straight	Straight	708102
1955-74	265, 283, 327, 350 engines without HEI distributor (wires route under exhaust manifold)	90°	Straight	708101
<b>CHEVROLET - GMC TRUCK</b>				
1970-74	250, 292 engines	Straight	90°	706101
1966-69	G10, 20 Vans with 6 cylinder engines	Straight	90°	706101
1963-69	C, K 10, 20, 30 with 6 cylinder engines	Straight	90°	706101
1974	454 engines	Straight	Straight	708102
1974	P Models with 400, 454 engines	90°	Straight	708103
1973-74	307, 350 engines	90°	Straight	708103
1972	1 Ton & Up with 366 engines	Straight	Straight	708102
1969-72	396, 402, 454 engines	Straight	Straight	708102
1955-72	283, 307, 327, 350 engines	90°	Straight	708101
<b>CHRYSLER</b>				
1979-89	5.2L 318, 5.9L 360 engines	Straight	90°	708105
1975-78	318, 340, 360 engines	Straight	90°	708105
1971-72	383, 400, 440 engines	90°	90°	708107
1971-72	Royal with 360 engines	Straight	90°	708105
1965-70	All 8 cylinder engines (excluding 1966 Imperial)	90°	90°	708107
1959-61	All 8 cylinder engines with Ram Induction (excluding Hemi engines)	90°	90°	708107
1955-58	All 8 cylinder engines (excluding Hemi engines)	Straight	90°	708105
<b>DODGE</b>				
1979-89	5.2L 318, 5.9L 360 engines.	Straight	90°	708105
1972-78	318, 340, 360 engines	Straight	90°	708105
1962-72	361, 383, 400, 440 engines	90°	90°	708107
1960-72	273, 318, 340, 360 engines	Straight	90°	708105
1960-62	383 engines with Ram Induction	90°	90°	708107
1956-57	All 8 cylinder engines (excluding Hemi engines)	Straight	90°	708105
<b>DODGE TRUCK</b>				
1974-89	5.2L 318, 5.6L 340, 5.9L 360 engines	Straight	90°	708105
1972-73	318, 360 engines with electronic ignition	Straight	90°	708105
1972-73	318, 360 engines with points ignition	90°	90°	708107
1961-71	318 engines	Straight	90°	708105
1961-71	383 engines	90°	90°	708107
<b>FORD</b>				
<b>Custom, Galaxie, LTD, Crown Victoria</b>				
1954-64	All 6 cylinder engines	Straight	90°	706101
1973-76	All 8 cylinder engines	Straight	90°	708104
1970-72	302, 351W engines	Straight	90°	708105
1970-72	351C, 390, 400, 429 engines	Straight	90°	708104
1968-69	302, 351 engines	Straight	90°	708105
1967-69	390, 427, 428, 429 engines	Straight	90°	708104
1954-67	All 8 cylinder engines (excluding 292 engines)	Straight	90°	708105
<b>Fairlane, Torino, LTD II, Ranchero</b>				
1954-73	All 6 cylinder engines	Straight	90°	706101
1975-76	302, 351W, 351C, 400 engines	Straight	90°	708104
1972-74	All 8 cylinder engines	Straight	90°	708104
1967-71	289, 302, 351W engines	Straight	90°	708105
1967-71	351C, 390, 429 engines	Straight	90°	708104
1962-66	All 8 cylinder engines (excluding 292 engines)	Straight	90°	708105
<b>Fairmont, Maverick</b>				
1975-76	200, 250 engines	Straight	90°	706101
1970-74	All 6 cylinder engines	Straight	90°	706101
1975-76	302 engines	Straight	90°	708104
1971-74	302 engines	Straight	90°	708105
<b>Falcon</b>				
1963-70	All 6 cylinder engines	Straight	90°	706101
1963-70	All 8 cylinder engines (excluding 292 engines)	Straight	90°	708105

Year	Make / Model / Engine	Plug Boot	Dist Boot	Part No.
<b>FORD (CONTINUED)</b>				
<b>Granada</b>				
1975-76	200, 250 engines	Straight	90°	706101
1975-76	302, 351W engines	Straight	90°	708104
<b>Mustang, Mustang II, Pinto</b>				
1965-73	All 6 cylinder engines	Straight	90°	706101
1975-76	302 engines	Straight	90°	708104
1972-73	302, 351C engines	Straight	90°	708104
1967-71	351, 390, 428, 429 engines	Straight	90°	708104
1965-71	289, 302 engines	Straight	90°	708105
<b>Thunderbird</b>				
1967-76	All 8 cylinder engines	Straight	90°	708104
1958-66	All 8 cylinder engines (excluding 292 engines)	Straight	90°	708105
<b>FORD TRUCK</b>				
1956-64	All 6 cylinder engines	Straight	90°	706101
1975-76	All 8 cylinder engines	Straight	90°	708104
1970-74	302 engines	Straight	90°	708105
1969-74	360, 390 engines	Straight	90°	708104
1969	302, 351 engines	Straight	90°	708105
1965-68	289, 302, 330, 352, 390 engines	Straight	90°	708105
1962	F-100, F-250 with 8 cylinder engines	Straight	90°	708104
<b>INTERNATIONAL TRUCK</b>				
1975-77	Scout, Traveller	Straight	90°	708104
1974	Scout, Travelall with 304 engine	Straight	90°	708104
<b>JEEP</b>				
1971-82	All 8 cylinder engines	Straight	Straight	708102
1968-71	J Series with 350 engines	Straight	Straight	708102
1966-68	J Series 327 engines	Straight	90°	708105
<b>LINCOLN</b>				
1975-76	460 engines	Straight	90°	708104
1961-74	All 8 cylinder engines	Straight	90°	708104
<b>MERCURY</b>				
<b>Marauder, Marquis, Monterey</b>				
1975-76	351C, 400, 460 engines	Straight	90°	708104
1965-74	All 8 cylinder engines	Straight	90°	708104
1961-64	All 8 cylinder engines	Straight	90°	708104
<b>Capri, Comet, Zephyr, Bobcat</b>				
1960-76	200, 250 engines	Straight	90°	706101
1975-76	302 engines	Straight	90°	708104
1971-74	All 8 cylinder engines	Straight	90°	708140
1963-70	221, 260, 289, 302 engines	Straight	90°	708105
<b>Cougar, XR-7</b>				
1972-76	351C, 351W, 400, 460 engines	Straight	90°	708104
1967-71	289, 302 engines	Straight	90°	708105
1967-71	390, 400, 427, 428 engines	Straight	90°	708104
<b>Monarch</b>				
1975-76	200, 250 engines	Straight	90°	706101
1975-76	302, 351W engines	Straight	90°	708104
<b>Montego</b>				
1968-73	All 6 cylinder engines	Straight	90°	706101
1975-76	351, 400, 460 engines	Straight	90°	708104
1971-74	All 8 cylinder engines	Straight	90°	708104
1968-70	289, 302, 351 engines	Straight	90°	708105
1968-70	390, 400, 427, 428 engines	Straight	90°	708104
<b>OLDSMOBILE</b>				
<b>88, 98, Delta 88, Toronado</b>				
1971-74	350, 455 engines without HEI distributor	Straight	90°	708105
1949-70	All 8 cylinder engines	Straight	90°	708105
<b>Calais, Ciera, Omega</b>				
1973-74	250 engines	Straight	90°	706101
1973-74	350 engines	Straight	90°	708105
<b>Cutlass Supreme, F85, 442</b>				
1968-74	All 6 cylinder engines	Straight	90°	706101
1968-74	350, 400, 455 engines	Straight	90°	708105
1964-67	330, 400 engines	Straight	90°	708105
<b>PLYMOUTH</b>				
1960-61	383 engines with Ram Induction	90°	90°	708107
1960-89	273, 318, 340, 360 engines.	Straight	90°	708105
1964-68	361, 383, 413, 426 engines (excluding Hemi engines)	90°	90°	708107
1969-72	383, 400, 440 engines	90°	90°	708107

Year	Make / Model / Engine	Plug Boot	Dist Boot	Part No.
<b>PONTIAC</b>				
<b>Bonneville, Catalina, Grand Prix</b>				
1972-74	350, 400, 455 engines	Straight	Straight	708102
1960-71	All 8 cylinder engines	Straight	Straight	708102
<b>Firebird, Trans Am, Formula, GTA</b>				
1967-74	All 6 cylinder engines	Straight	90°	706101
1967-74	All 8 cylinder engines	Straight	Straight	708102
<b>Fiero, Grand Am, Phoenix, Sunbird, Ventura, J-2000, 6000, STE</b>				
1971-74	All 6 cylinder engines	Straight	90°	706101
1971-74	All 8 cylinder engines without HEI distributor	Straight	Straight	708102
<b>Tempest, LeMans, GTO</b>				
1964-74	All 6 cylinder engines	Straight	90°	706101
1964-74	All 8 cylinder engines without HEI distributor	Straight	Straight	708102
1962-63	All 8 cylinder engines	Straight	90°	708105
<b>VOLKSWAGEN</b>				
1961-79	All 4 cylinder type 1 engines (Black Wires) No Script	Straight	Straight	704101
1961-79	All 4 cylinder type 1 engines (Blue Wires) With Flame-Thrower Script	Straight	Straight	704301
1961-79	All 4 cylinder type 1 engines (Red Wires) With Flame-Thrower Script	Straight	Straight	704401
1961-79	All 4 cylinder type 1 engines (Yellow Wires) With Flame-Thrower Script	Straight	Straight	704501

## 7MM "STOCK-LOOK" UNIVERSAL SPARK PLUG WIRES

Universal 7mm spark plug wire kits have the same great features our pre-made kits have and are available with either 90° or straight spark plug boots. Each universal set includes terminals for both male and female terminal distributor caps. These kits come with extra long wires to accommodate most application.



Description	Plug Boot	Dist Boot	Part No.
Universal 8 cylinder	Straight	90°	708180
Universal 8 cylinder	90°	90°	708190

## 7MM "STOCK-LOOK" SPARK PLUG WIRE BY THE SPOOL

We've designed our 7mm wire with the same core we use in our 8mm wire. The only difference is the 7mm flat black silicone jacket which hides its performance potential from the naked eye. Get the best of both worlds with "state-of-the-art performance and a stock look." Each spool has 100 feet of wire, enough for four to five V8 engines.



Description	Part No.
100' Spool 7mm "Stock-Look" Spark Plug Wire	70S210

**NEW**

70S210

**INDUSTRIAL DISTRIBUTORS**

PerTronix is the leading producer of electronic distributors for gas, propane and LP powered industrial engines. Many Wisconsin and Continental engines are equipped with our industrial distributors from the factory. Proven performance, reduced maintenance downtime, improved economy, faster starts and extended tune-up intervals. Our industrial distributors are also direct replacements for many point type Delco, and Prestolite distributors.

**FEATURES**

- Durable yet lightweight housing.
- Integrated Ignitor Electronic technology.
- Superior venting system.
- 'O' ring seal prevents oil leakage.
- Precision engineered module switches 2 times more energy than other electronic ignition system.
- Timing remains constant with an amazing 1/4° accuracy all the way down to zero RPM.
- Effective RPM range of 0 to 6000.
- Non-tracking cap and rotor.
- Warranty: 30 months Ignitor module / 90 days mechanical.



**NEVER CHANGE POINTS AGAIN!**



**INDUSTRIAL DISTRIBUTORS**

Year	Cyl	Model - Series	Part No.
<b>ALLIS CHALMERS</b>			
1969-74	4	All Models with clockwise distributor	D41-19A
<b>CONTINENTAL</b>			
All	3	TM-20 engine Models	D33-03A
All	4	TM-27 engine Models	D43-04B
1940-65	4	F4 Series F124, F4124, F140, F4140, FA140 F162, F4162, FA162	D41-05A
1965-present	4	F4 Series F135, F163	D41-05A
1965-present	4	Y4 Series Y69, Y91, Y112, YA112, IY112, Y4069, Y4091, Y4112	D41-05A
1940-65	6	F6 Series F170, F186, F209, F218, F224, F226, F244, F6170, F6186, F6209, F6226, F6244	D61-06A
1965-present	6	F6 Series F227, F245, F6227	D61-06A
4 cylinder and 6 cylinder Continental distributors replace the original Prestolite and/or Delco-Remy distributors in F4, F6 and Y4 series engines manufactured since 1965 and require no modifications. On engines prior to 1965 some modifications may be necessary.			
<b>PERKINS</b>			
1992 prior	4	G4236 engine	D41-20A
<b>WAUKESHA</b>			
1970-92	4	D155G, D176G, VRG220	D41-01A
<b>WISCONSIN</b>			
1955-present	1	Model BKN	D11-18A
1957-present	1	Model AENL	D11-18A
1968-present	2	Model TJD	D21-12A
1980-present	2	Model W2-1230, W2-1235	D21-11A
1980-present	2	Model W2-880	D21-12A
1987-present	2	Model W2-1250	D21-11A
1956-present	4	Model VH4D (side mount)	D41-09B
1956-present	4	Model VH4D (top mount)	D41-10B
1967-present	4	Model V65D (side mount)	D41-09B
1975-present	4	Model W4-1770 (top mount)	D41-10B
1976-present	4	Model W4-1770 (side mount)	D41-09B



Original Dist No.	PerTronix Dist No.
<b>CLARK</b>	
1636495	D41-01A
2372353	D41-01A
914528	D43-04B
<b>COLT</b>	
FMD1C7	D11-18A
FMD2C7	D21-12A
FMD2C7-B	D21-11A
FMD4C7	D41-09B
FMD427A	D41-10B
<b>CONTINENTAL</b>	
F162M-00232	D41-05A
F162M-00311	D41-05A
F162M-00315	D41-05A
F162M-00347	D41-05A
F162M-00412	D41-05A
F162M-00446	D41-05A
F162M-00462	D41-05A
F162M-00466	D41-05A
F186M-00202	D61-06A
F226M-00304	D61-06A
F226M-00309	D61-06A
F226M-00404	D61-06A
F226M-00407	D61-06A
F226M-00416	D61-06A
F226M-00421	D61-06A
F226M-00424	D61-06A
F226M-00433	D61-06A
F226M-00436	D61-06A
F244M-00406	D61-06A
F244M-00414	D61-06A
F244M-00523	D61-06A
F226M-00503	D61-06A
F400M-00305	D41-05A
F400M-00307	D41-05A
F400M-00392	D41-05A
F400M-00533	D41-05A
F400M-00411	D41-05A
F400M-00413	D41-05A
F400M-00449	D41-05A
F400M-00466	D41-05A
F400M-00472	D41-05A
F400M-00503	D41-05A
F400M-00507	D41-05A
F400M-00516	D41-05A
F400M-00518	D41-05A
F400M-00521	D41-05A
F400M-00531	D41-05A
F400M-00532	D41-05A
F401M-00405	D41-05A
F401M-00406	D41-05A
F600M-00305	D61-06A
F600M-00314	D61-06A
F600M-00373	D61-06A
F600M-00380	D61-06A
F600M-00405	D61-06A
F600M-00439	D61-06A
F600M-00440	D61-06A
F600M-00449	D61-06A
F600M-00451	D61-06A
F600M-00502	D61-06A
F600M-00508	D61-06A
F600M-00509	D61-06A
F600M-00510	D61-06A
F600M-00518	D61-06A
F600M-00519	D61-06A
F600M-00525	D61-06A
TM13M-00501	D23-02A
TM20M-00500	D33-03A
TM20M-00501	D33-03A
TM20M-00503	D33-03AM

Original Dist No.	PerTronix Dist No.
<b>CONTINENTAL</b>	
TM27M-00502	D43-04B
TM27M-00503	D43-04B
TM27M-00510	D43-04B
TM27M-00511	D43-04BM
Y112M-00237	D41-05A
Y112M-00305	D41-05A
Y112M-00500	D41-05A
Y400M-00281	D41-05A
Y112M-00311	D41-05A
Y91M-00411	D41-05A
<b>DELCO</b>	
1110021	D61-06A
1110060	D61-06A
1110305	D61-06A
1110306	D41-05A
1110402	D41-05A
1110420, 23	D41-05A
1111310	D41-05A
1111356	D41-05A
1111428	D41-05A
1111429	D61-06A
1111432	D41-05A
1111576	D41-05A
1111620	D61-06A
1111700	D41-01A
1111712	D41-05A
1111716, 17	D41-05A
1111728	D61-06A
1111769	D61-12A
1111870	D61-12A
1111895	D61-06A
1111913	D61-06A
1112461	D61-19B
1112508	D61-06A
1112552	D61-06A
1112567	D61-06A
1112604	D41-05A
1112628	D61-06A
1112637	D41-05A
1112672	D61-06A
1112673	D41-05A
1112685	D41-01A
1112789	D41-05A
<b>MALLORY</b>	
YL-664A	D41-01A
<b>PRESTOLITE</b>	
IAD-4029, A	D41-05A
IAD-4033	D61-06A
IAD-6002-1F	D61-06A
IAD-6003-2H	D41-05A
IAD-6004-1E	D41-05A
IAD-6004-2F, N	D41-09B
IAD-6004-2P	D41-10B
IAD-6006-1	D61-06A
IBT-4101H	D41-05A
IBT-4105A	D41-01A
IBT-4105B	D41-05A
IBT-4106, E	D41-27A
IBT-4106A	D41-28A
IBT-4106B, C, D	D41-26A
IBT-4201	D21-11A
IBT-4705	D41-05A
IBT-4706	D41-05A
IBT-6501D	D61-06A
IBT-6702, 03	D61-06A
IDJ-4008	D41-05A
IDJ-4012	D41-05A
IDJ-4013, 14	D61-06A
IDN-4012	D43-04B
IDN-4014	D33-03A

Original Dist No.	PerTronix Dist No.
<b>PRESTOLITE</b>	
IDU-4403A, B	D41-01A
IDU-4406, 08	D41-20A
IGB-4045A	D41-05A
IGB-4304B	D61-06A
IGC-4722	D61-06A
IGC-6004-1	D41-05A
IGW-4139, C	D41-05A
IGW-4156A	D41-05A
IGW-4408	D11-18A
IGW-4412	D21-12A
IGW-6581B	D41-05A
<b>WAUKESHA</b>	
60262K	D41-01A
69748A	D41-01A
<b>WISCONSIN</b>	
YF-10C	D41-09B
YF-10D	D41-10B
YF-35	D21-12A
YF-40	D21-12A
YF-42	D21-11A
YF-45	D41-09B
YF-45A	D41-10B
YF-46	D21-12A
YF-48	D21-11A
YF-49	D11-18A
YF-50, YF-50C	D41-09B
YF-50A, YF-50D	D41-10B
YF-50B, YF-50E	D41-11B
YF-51, YF-51A	D21-11A
YF-52, YF-52A	D21-12A
YF-53	D11-18A
YF-54, YF-54A	D21-13A
YF-55, YF-55A	D41-24A
YF-8C	D11-18A



D41-05A



D61-06A

**DISTRIBUTOR DIMENSIONS**

Distributor Number	Dim. A	Dim. B	Dim. C	Dim. D	Dim. E	Drive	Rotation
D11-18A	6.30	2.67	1.06	----	----	----	CCW
D21-11A	8.29	2.85	1.06	----	----	GEAR	CW
D21-12A	7.88	2.46	1.06	----	----	GEAR	CCW
D23-02A	9.21	2.71	1.06	1.36	1.05	GEAR	CCW
D33-03A	9.51	2.71	1.06	1.36	1.05	GEAR	CCW
D33-03AM	9.51	2.71	1.06	1.36	1.05	GEAR	CCW
D41-01A	8.55	2.34	1.06	1.60	1.12	TANG	CW
D41-05A	7.58	1.31	1.06	1.36	1.05	TANG	CCW
D41-09B	7.88	2.62	1.06	----	----	GEAR	CCW
D41-10B	7.88	2.66	1.06	----	----	GEAR	CCW
D41-19A	8.80	2.53	1.06	1.60	1.12	TANG	CW
D41-20A	8.25	2.13	1.06	1.69	1.05	GEAR	CCW
D43-04B	9.21	2.71	1.06	1.36	1.05	GEAR	CCW
D61-06A	7.64	1.31	1.06	1.36	1.05	TANG	CCW

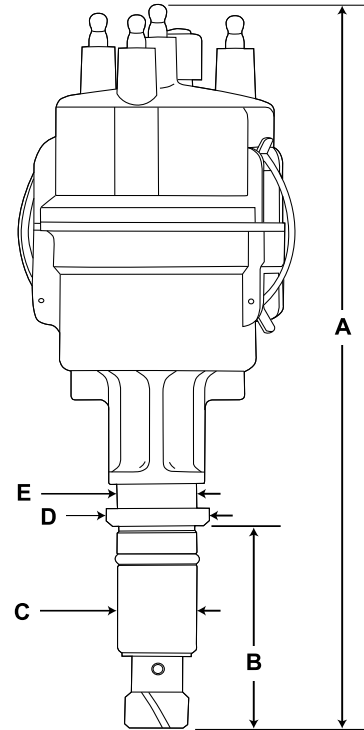

D41-05A



D41-09B

**SERVICE PARTS**

Keep that engine in your hard working equipment running strong by using high quality service parts from PerTronix. We have a complete selection of service parts to fit our industrial distributors. These parts can also be used to service many original equipment distributors found in Wisconsin and Continental engines.



Dist. Number	Cap	Rotor	Cap Gasket	Dust Cover	Magnet Sleeve	Module	Drive	Advance Spring	Advance Weight	Vac. Advance
D11-18A	022-1101	N/A	027-001	N/A	026-101	025-004B	N/A	N/A	019-1001	N/A
D21-11A	022-1203	020-1002	027-001	021-001	026-202	025-005B	023-1002	018-1005	019-1003	N/A
D21-12A	022-1202	020-1002	027-001	021-001	026-201	025-004B	023-1003	018-1004	019-1001	N/A
D21-13A	022-1204	020-1002	027-001	021-001	026-203	025-004B	023-1003	018-1004	N/A	N/A
D23-02A	022-1201	020-1001	027-002	021-001	026-201	025-002B	023-1001	018-1001	019-1001	N/A
D33-03A	022-1301	020-1001	027-002	021-001	026-301	025-002B	023-1001	018-1001	019-1001	024-001
D33-03AM	022-1301	020-1001	027-002	021-001	026-301	025-006B	023-1001	018-1001	019-1001	N/A
D41-01A	022-1403	020-1003	027-001	021-001	026-401	025-008A	023-1004	018-1007	019-1003	N/A
D41-05A	022-1403	020-1003	027-001	021-001	026-401	025-003A	023-1005	018-1002	019-1001	N/A
D41-09B	022-1403	020-1002	027-001	021-001	026-401	025-003A	023-1002	018-1003	019-1001	N/A
D41-10B	022-1403	020-1002	027-001	021-001	026-401	025-003A	023-1002	018-1003	019-1001	N/A
D41-19A	022-1403	020-1003	027-001	021-001	026-401	025-007A	023-1006	018-1008	019-1003	N/A
D41-20A	022-1403	020-1003	027-001	021-001	026-401	025-003A	023-1007	018-1009	019-1001	N/A
D43-04B	022-1404	020-1001	027-002	021-001	026-401	025-001A	023-1001	018-1001	019-1001	024-001
D61-06A	022-1602	020-1003	027-001	021-001	026-601	025-003A	023-1005	018-1002	019-1001	N/A
D61-19B	022-1602	020-1003	027-001	021-001	026-601	025-007A	N/A	018-1008	019-1003	N/A



**PerTronix Ignition Brands**

**Flame-Thrower<sup>®</sup>**

Ignition Coils · Spark Plug Wires  
HEI and Billet Distributors  
Ignition Modules

**Second Strike<sup>®</sup>** **DigitalREV Limiter**

Multi-Spark CD Box

Digital Rev Control Box

**Ignitor<sup>®</sup> III**

Ignition box performance... without the "box"!

**Ignitor<sup>®</sup> II**

Micro-controlled Electronic Ignition  
for point type distributors

**IGNITOR<sup>®</sup>**

Solid-State Electronic Ignition  
for point type distributors



**PerTronix Exhaust Brands**

*The original*  
**DOUG'S HEADERS**

Muscle Car and Street Rod Headers



**JBA**  
performance**exhaust**

Late Model Truck, SUV and Passenger Car  
Headers & Exhaust Systems

**PATRIOT<sup>®</sup>**

Street Rod and Muscle Car Headers  
Side Exhaust · Do-It-Yourself Products

**Smithy's<sup>®</sup>**

The Original Smithy's Mufflers

**Thunderbird**

Air Cooled VW Exhaust Products

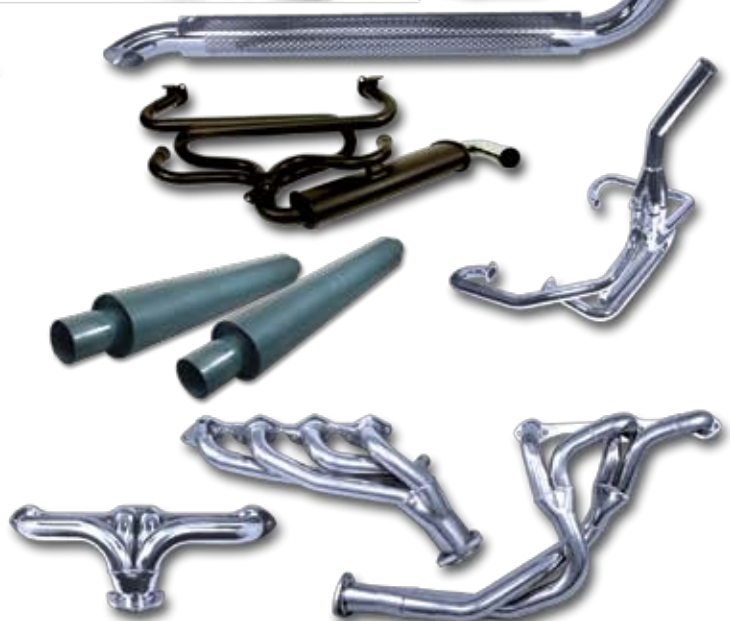

***Your Complete Source For  
Ignition Products!***



***AUTOMOTIVE  
AGRICULTURAL  
INDUSTRIAL  
MARINE***

***PerTronix Performance Products***

---

**440 East Arrow Highway  
San Dimas, CA 91773  
Phone: (909) 599-5955  
Fax: (909) 599-6424  
[www.pertronix.com](http://www.pertronix.com)**